



MODEL M1113
18" WOOD/METAL BANDSAW



OWNER'S MANUAL

Phone: (360) 734-3482 • Online Technical Support: tech-support@shopfox.biz

COPYRIGHT © OCTOBER, 2007 BY WOODSTOCK INTERNATIONAL, INC.

**WARNING: NO PORTION OF THIS MANUAL MAY BE REPRODUCED IN ANY SHAPE OR FORM WITHOUT
THE WRITTEN APPROVAL OF WOODSTOCK INTERNATIONAL, INC.**



WARNING!

This manual provides critical safety instructions on the proper setup, operation, maintenance and service of this machine/equipment.

Failure to read, understand and follow the instructions given in this manual may result in serious personal injury, including amputation, electrocution or death.

The owner of this machine/equipment is solely responsible for its safe use. This responsibility includes but is not limited to proper installation in a safe environment, personnel training and usage authorization, proper inspection and maintenance, manual availability and comprehension, application of safety devices, blade/cutter integrity, and the usage of personal protective equipment.

The manufacturer will not be held liable for injury or property damage from negligence, improper training, machine modifications or misuse.



WARNING!

Some dust created by power sanding, sawing, grinding, drilling, and other construction activities contains chemicals known to the State of California to cause cancer, birth defects or other reproductive harm. Some examples of these chemicals are:

- Lead from lead-based paints.
- Crystalline silica from bricks, cement and other masonry products.
- Arsenic and chromium from chemically-treated lumber.

Your risk from these exposures varies, depending on how often you do this type of work. To reduce your exposure to these chemicals: Work in a well ventilated area, and work with approved safety equipment, such as those dust masks that are specially designed to filter out microscopic particles.

Contents

INTRODUCTION	2	ACCESSORIES	36
Woodstock Technical Support.....	2	MAINTENANCE	37
SAFETY	6	Schedule	37
Standard Safety Instructions	6	Cleaning	37
Additional Safety for Bandsaws.....	8	Table & Base.....	37
ELECTRICAL	9	Redressing Rubber Tires	37
220V Operation	9	SERVICE	38
Extension Cords	9	General	38
Electrical Specifications	9	Servicing V-Belts	38
SETUP	10	Shimming Table	40
Inventory	10	Blade Lead	40
Machine Placement	11	Wheel Alignment	42
Cleaning Machine.....	11	Electrical Component Wiring.....	44
Lifting & Moving.....	12	Wiring Diagram	45
Mounting to Shop Floor	13	Troubleshooting	46
Assembly.....	14	PARTS	48
Dust Collection	16	Bandsaw Body Breakdown	48
Blade Tracking.....	17	Bandsaw Body Parts List	49
Test Run	18	Table & Guides Breakdown.....	50
Blade Tensioning	19	Table & Guides Parts List.....	51
Support Bearing Adjustment	20	Fence Breakdown	52
Blade Guide Adjustment	21	Label Placement	53
Table Stop Adjustment.....	22		
Table Tilt Scale Calibration	22		
Table Alignment.....	23		
Fence Alignment	23		
OPERATIONS	24		
General	24		
Basic Controls.....	24		
Workpiece Inspection (Wood).....	25		
Workpiece Inspection (Metal).....	26		
Cutting Overview.....	27		
Table Tilt	27		
Guide Post.....	28		
Rip Cutting	28		
Crosscutting.....	29		
Resawing.....	29		
Cutting Curves	30		
Stacked Cuts	30		
Blade Characteristics (Wood Cutting)	31		
Blade Selection (Metal Cutting)	33		
Blade Changes	34		
Fence Scale Calibration	35		





INTRODUCTION

Woodstock Technical Support

This machine has been specially designed to provide many years of trouble-free service. Close attention to detail, ruggedly built parts and a rigid quality control program assure safe and reliable operation.

Woodstock International, Inc. is committed to customer satisfaction. Our intent with this manual is to include the basic information for safety, setup, operation, maintenance, and service of this product.

We stand behind our machines! In the event that questions arise about your machine, please contact Woodstock International Technical Support at (360) 734-3482 or send e-mail to: tech-support@shopfox.biz. Our knowledgeable staff will help you troubleshoot problems and process warranty claims.

If you need the latest edition of this manual, you can download it from <http://www.shopfox.biz>.
If you have comments about this manual, please contact us at:

Woodstock International, Inc.
Attn: Technical Documentation Manager
P.O. Box 2309
Bellingham, WA 98227
Email: manuals@woodstockint.com

MACHINE SPECIFICATIONS



Phone #: (360) 734-3482 • Online Tech Support: tech-support@shopfox.biz • Web: www.shopfox.biz

MODEL M1113 18" WOOD/METAL CUTTING BANDSAW

Motor:

Horsepower	1.5 HP
Voltage	220V
Phase	3-Phase
Cycle	60 Hz
Type	Induction
Amps	5
Speed	1725 RPM
Bearings	Shielded and Permanently Lubricated
Power Transfer	V-Belt Drive

Main Specifications:

Throat Capacity Left-of-Blade	17 ¹ / ₂ "
Maximum Resaw Height	12"
Blade Speeds	Variable 150-3000 FPM
Blade Length	133"
Blade Width Range	1/ ₈ "-1 ¹ / ₄ "
Table Size (Length, Width, Thickness)	18" (+6") x 18" x 1 ³ / ₄ "
Table Tilt	-5° to 45°
Table Height from Floor	37 ¹ / ₄ "
Wheel Diameter	18"
Number of Dust Ports	2
Dust Port Size	4" x 2
Fence Locking Location	Front

Overall Dimensions

Weight	341 lbs.
Length/Width/Height	30" x 41" x 74"
Footprint (Length/Width)	41" x 30"

Construction Materials

Wheels	Fully Balanced Aluminum
Wheel Covers	Steel
Table	Precision Ground Cast Iron
Fence	Aluminum
Guides	Steel Blocks
Base	Steel
Body	Steel
Paint	Powder Coated



Shipping Specifications

Type of Container Wood Slat Crate
 Container Content Machine
 Weight 429 lbs.
 Length/Width/Height 32¹/₄" x 19¹/₄" x 79"

Electrical

Required Power Source 220V, Single-Phase
 Inverter Type Rhymebus RMG5
 Inverter Size 1 HP
 Switch ON/OFF Push Button w/Large STOP Paddle
 Cord Length 6 ft.
 Cord Gauge 16 gauge
 Recommended Circuit Size 15 amp
 Plug Included No
 Recommended Plug 6-15

Other

Compatible Shop Fox Mobile Base D2058
 Country Of Origin Taiwan
 Sound Rating 74 dB
 Warranty 1 Year
 Serial Number Location ID Label on Center of Upper Wheel Cover
 Approximate Assembly & Setup Time 1 Hours

Controls and Features

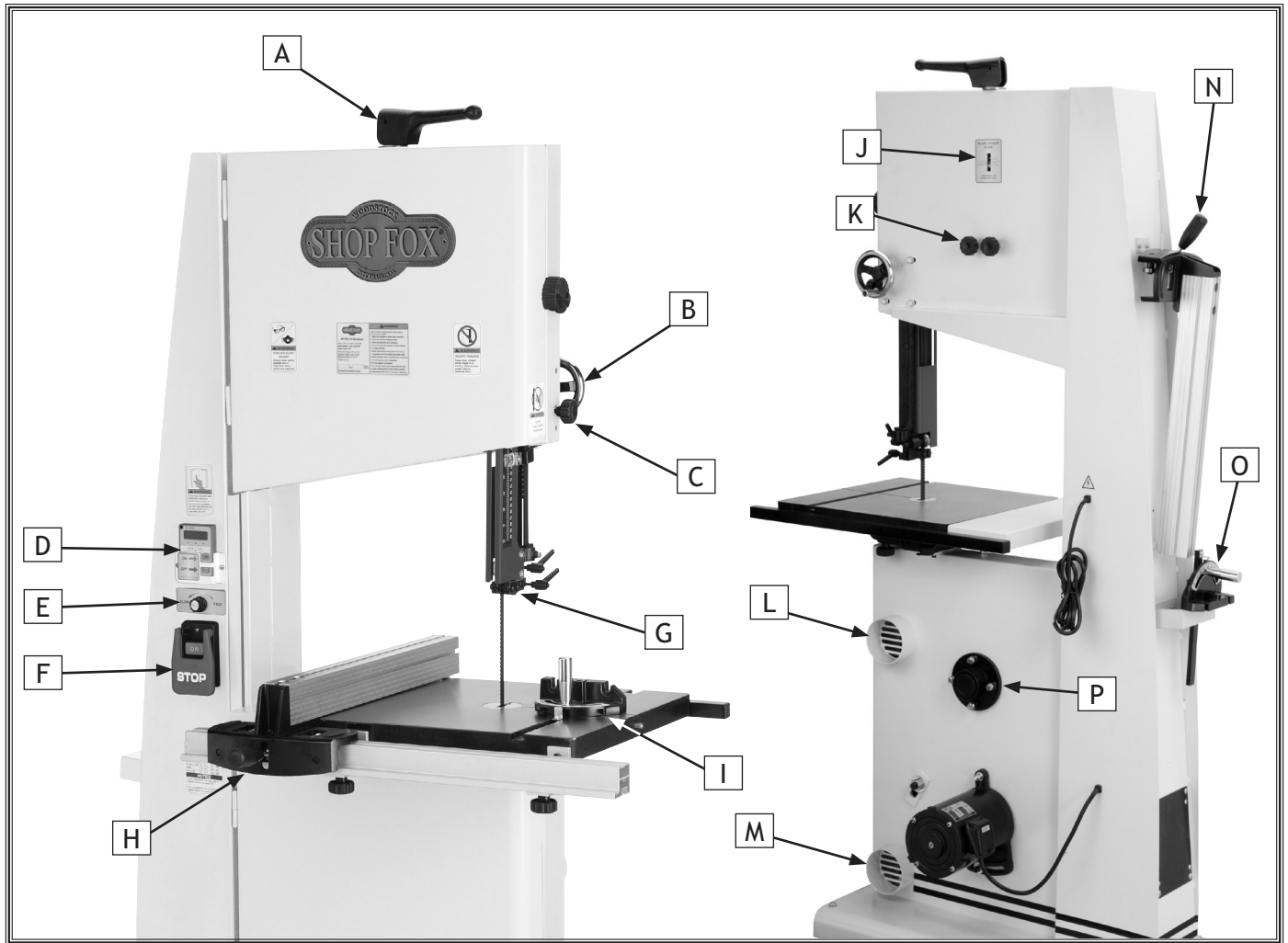

- A. Blade Tension Lever
- B. Blade Guide Elevation Handwheel
- C. Blade Guide Elevation Lock Knob
- D. Motor Switch
- E. Speed Dial
- F. Power Switch
- G. Upper Blade Guide Assembly
- H. Fence

- I. Miter Gauge
- J. Blade Tension Scale
- K. Blade Tracking Knobs
- L. Upper 4" Dust Port
- M. Lower 4" Dust Port
- N. Fence Holder
- O. Miter Gauge Holder
- P. Lower Wheel Adjustment Hub

SAFETY

**READ MANUAL BEFORE OPERATING MACHINE.
FAILURE TO FOLLOW INSTRUCTIONS BELOW WILL
RESULT IN PERSONAL INJURY.**



Indicates an imminently hazardous situation which, if not avoided, **WILL** result in death or serious injury.



Indicates a potentially hazardous situation which, if not avoided, **COULD** result in death or serious injury.



Indicates a potentially hazardous situation which, if not avoided, **MAY** result in minor or moderate injury.

NOTICE

This symbol is used to alert the user to useful information about proper operation of the equipment, and/or a situation that may cause damage to the machinery.

Standard Safety Instructions

1. **READ THROUGH THE ENTIRE MANUAL BEFORE STARTING MACHINERY.** Machinery presents serious injury hazards to untrained users.
2. **ALWAYS USE ANSI APPROVED SAFETY GLASSES WHEN OPERATING MACHINERY.** Everyday eye-glasses only have impact resistant lenses—they are NOT safety glasses.
3. **ALWAYS WEAR AN NIOSH APPROVED RESPIRATOR WHEN OPERATING MACHINERY THAT PRODUCES DUST.** Wood dust is a carcinogen and can cause cancer and severe respiratory illnesses.
4. **ALWAYS USE HEARING PROTECTION WHEN OPERATING MACHINERY.** Machinery noise can cause permanent hearing damage.
5. **WEAR PROPER APPAREL.** DO NOT wear loose clothing, gloves, neckties, rings, or jewelry which may get caught in moving parts. Wear protective hair covering to contain long hair and wear non-slip footwear.
6. **NEVER OPERATE MACHINERY WHEN TIRED, OR UNDER THE INFLUENCE OF DRUGS OR ALCOHOL.** Be mentally alert at all times when running machinery.
7. **ONLY ALLOW TRAINED AND PROPERLY SUPERVISED PERSONNEL TO OPERATE MACHINERY.** Make sure operation instructions are safe and clearly understood.
8. **KEEP CHILDREN AND VISITORS AWAY.** Keep all children and visitors a safe distance from the work area.
9. **MAKE WORKSHOP CHILD PROOF.** Use padlocks, master switches, and remove start switch keys.

10. **NEVER LEAVE WHEN MACHINE IS RUNNING.** Turn power off and allow all moving parts to come to a complete stop before leaving machine unattended.
11. **DO NOT USE IN DANGEROUS ENVIRONMENTS.** DO NOT use machinery in damp, wet locations, or where any flammable or noxious fumes may exist.
12. **KEEP WORK AREA CLEAN AND WELL LIT.** Clutter and dark shadows may cause accidents.
13. **USE A GROUNDED EXTENSION CORD RATED FOR THE MACHINE AMPERAGE.** Undersized cords over-heat and lose power. Replace extension cords if they become damaged. DO NOT use extension cords for 220V machinery.
14. **ALWAYS DISCONNECT FROM POWER SOURCE BEFORE SERVICING MACHINERY.** Make sure switch is in OFF position before reconnecting.
15. **MAINTAIN MACHINERY WITH CARE.** Keep blades sharp and clean for best and safest performance. Follow instructions for lubricating and changing accessories.
16. **MAKE SURE GUARDS ARE IN PLACE AND WORK CORRECTLY BEFORE USING MACHINERY.**
17. **REMOVE ADJUSTING KEYS AND WRENCHES.** Make a habit of checking for keys and adjusting wrenches before turning machinery ON.
18. **CHECK FOR DAMAGED PARTS BEFORE USING MACHINERY.** Check for binding and alignment of parts, broken parts, part mounting, loose bolts, and any other conditions that may affect machine operation. Repair or replace damaged parts.
19. **USE RECOMMENDED ACCESSORIES.** Refer to the instruction manual for recommended accessories. The use of improper accessories may cause risk of injury.
20. **DO NOT FORCE MACHINERY.** Work at the speed for which the machine or accessory was designed.
21. **SECURE WORKPIECE.** Use clamps or a vise to hold the workpiece when practical. A secured workpiece protects your hands and frees both hands to operate the machine.
22. **DO NOT OVERREACH.** Keep proper footing and balance at all times.
23. **MANY MACHINES WILL EJECT THE WORKPIECE TOWARD THE OPERATOR.** Know and avoid conditions that cause the workpiece to "kickback."
24. **ALWAYS LOCK MOBILE BASES (IF USED) BEFORE OPERATING MACHINERY.**
25. **BE AWARE THAT CERTAIN DUST MAY BE HAZARDOUS** to the respiratory systems of people and animals, especially fine dust. Make sure you know the hazards associated with the type of dust you will be exposed to and always wear a respirator approved for that type of dust.

Additional Safety for Bandsaws

SAFETY



! WARNING
 READ and understand this entire instruction manual before using this machine. Serious personal injury may occur if safety and operational information is not understood and followed. **DO NOT** risk your safety by not reading!

! CAUTION
 USE this and other machinery with caution and respect. Always consider safety first, as it applies to your individual working conditions. No list of safety guidelines can be complete—every shop environment is different. Failure to follow guidelines could result in serious personal injury, damage to equipment or poor work results.

1. **BLADE CONDITION.** Do not operate with a dull, cracked, or badly worn blade. Dull blades require more effort to use and are difficult to control. Inspect blades for cracks and missing teeth before each use, and replace if necessary.
2. **HAND PLACEMENT.** Never position fingers or thumbs in line with the cut. Serious personal injury could occur.
3. **GUARDS.** Do not operate this bandsaw without the blade guard in place.
4. **BLADE REPLACEMENT.** When replacing blades, make sure the teeth face down, toward the front of the saw and the blade is properly tensioned before operating.
5. **WORKPIECE HANDLING.** Never hold small workpieces with your fingers when cutting. Always support/feed the workpiece with a push stick, table support, vise, or some type of clamping fixture.
6. **CUTTING TECHNIQUES.** Plan your cuts carefully. **DO NOT** back the workpiece away from the blade while the saw is running. If you need to back the work out, turn the bandsaw **OFF** and wait for the blade to come to a complete stop. **DO NOT** twist or put excessive stress on the blade while backing work away.
7. **BLADE SPEED.** Allow blade to reach full speed before cutting.
8. **LEAVING WORK AREA.** Never leave a machine running while unattended. Allow the bandsaw to come to a complete stop before leaving unattended.
9. **FEED RATE.** Always feed stock evenly and smoothly. **DO NOT** force or twist blade while cutting, especially when sawing tight curves.
10. **MAINTENANCE/SERVICE.** Do all inspections, adjustments, and maintenance with the machine turned **OFF** and disconnected from the power source.
11. **BLADE CONTROL.** Do not attempt to stop or slow the blade with your hand or a workpiece. Allow the blade to stop on its own.
12. **EXPERIENCING DIFFICULTIES.** If you experience difficulties performing the intended operation, stop using the machine and contact our Technical Support Department at (570) 546-9663.

ELECTRICAL

⚠️ WARNING
 The machine must be properly set up before it is safe to operate. **DO NOT** connect this machine to the power source until instructed to do so in the "Test Run" portion of this manual.

220V Operation

The Model M1113 operates on 220V single-phase power. We recommend connecting this machine to a dedicated circuit with a verified ground, using the circuit size given below. Never replace a circuit breaker with one of higher amperage without consulting a qualified electrician to ensure compliance with wiring codes. This machine must be connected to a grounded circuit!

A plug is not supplied with this machine. See below for the recommended plug type for this machine.

If you are unsure about the wiring codes in your area or you plan to connect your machine to a shared circuit, you may create a fire or circuit overload hazard—consult a qualified electrician to reduce this risk.

Extension Cords

We do not recommend using an extension cord; however, if you have no alternative, use the following guidelines:

- Use a cord rated for Standard Service (S).
- Do not use an extension cord longer than 50 feet.
- Ensure that the cord has a ground wire and pin.
- Use the gauge size listed below as a minimum.

Electrical Specifications

Operating Voltage	Amp Draw	Min. Circuit Size	Recommended Plug	Extension Cord
220V Single-Phase	5 Amps	15A	NEMA 6-15 (not incl.)	14 Gauge

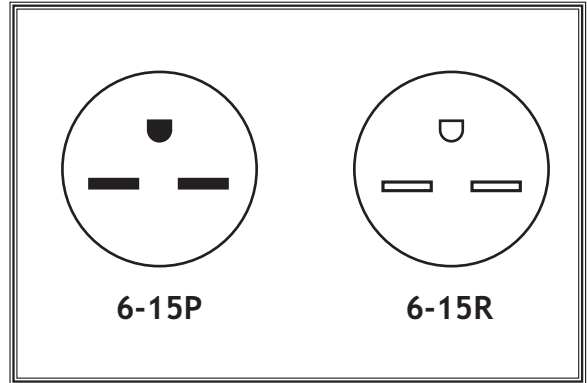

Figure 1. 6-15 plug and receptacle.

⚠️ WARNING

DO NOT work on your electrical system if you are unsure about electrical codes and wiring! Seek assistance from a qualified electrician. Ignoring this warning can cause electrocution, fire, or machine damage.

ELECTRICAL

SETUP

Inventory

This machine has been carefully packaged for safe transportation. If you notice the machine has been damaged during shipping, please contact your authorized Shop Fox dealer immediately. The following is a description of the main components shipped with the Model M1113.

Note: *If you can't find an item on this list, check the mounting location on the machine or examine the packaging materials carefully. Occasionally we pre-install certain components for safer shipping.*

Main Components: (Figure 2)	Qty
A. Table	1
B. Table Extension.....	1
C. Table Insert	1
D. Rear Rail	1
E. L-Brackets	2
F. Front Rail	1
G. Fence Assembly.....	1
H. Miter Gauge Holder	1
I. Miter Gauge	1

Fasteners, Tools, & Miscellaneous: (Figure 3)	Qty
• Hex Bolts $\frac{5}{16}$ "-18 x 2" (Table Extension)	2
• Hex Nuts $\frac{5}{16}$ "-18 (Table Extension)	2
• Flat Washers $\frac{5}{16}$ " (Table Extension)	4
• Knobs $\frac{3}{8}$ "-16 (Table Trunnion)	2
• Cap Screws M6-1 x 16 (Rear Rail to Table)	2
• Cap Screws M6-1 x 16 (L-Brackets to Table).....	2
• Knobs $\frac{5}{16}$ "-18 x $\frac{5}{8}$ " (L-Bracket to Front Rail)	2
• T-Slot Nuts $\frac{5}{16}$ " (L-Bracket to Front Rail)	2
• Scale (Front Rail).....	1
• Guide Blocks (Blade Guides).....	6
• Thumb Screws $\frac{1}{4}$ "-20 x $\frac{1}{2}$ " (Blade Guides)	6
• Hex Wrenches 3 and 5mm	1 each
• Flat Wrench 12/14mm.....	1

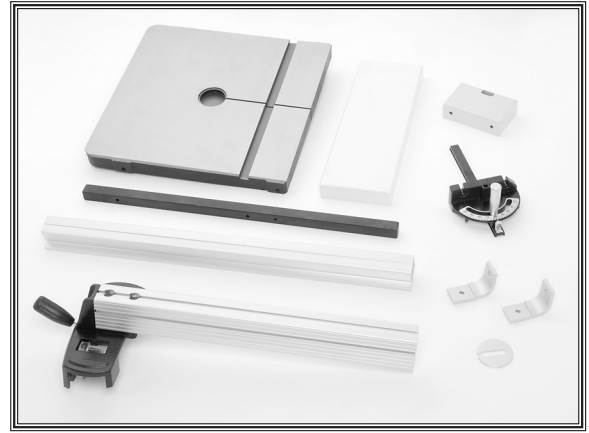
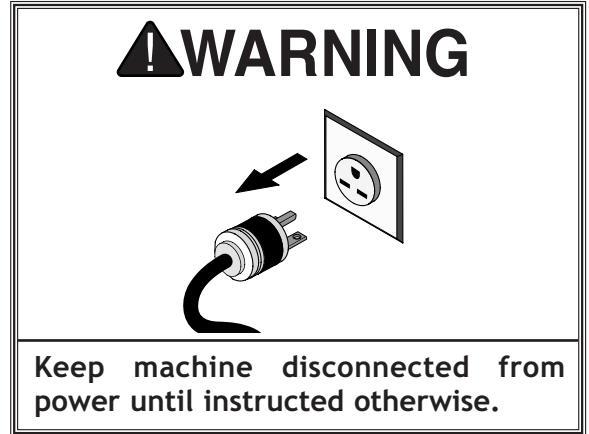

Figure 2. Main component inventory.



Figure 3. Fasteners, tools, & miscellaneous item inventory.

SETUP

Machine Placement

- **Floor Load:** This machine distributes a heavy load in a small footprint. Some residential floors may require additional bracing to support both machine, operator, and material to be processed.
- **Working Clearances:** Consider existing and anticipated needs, size of material to be processed through the machine, and space for auxiliary stands, work tables or other machinery when establishing a location for your bandsaw. Refer to **Figure 4**.
- **Lighting:** Lighting should be bright enough to eliminate shadow and prevent eye strain.
- **Electrical:** Place the machine near a power source to avoid long runs of power cords strung across your shop. Refer to the **Electrical** section on **Page 9** for information on minimum circuit requirements.

Cleaning Machine

The table and other unpainted parts of your machine type are coated with a waxy grease that protects them from corrosion during shipment. Clean this grease off with a solvent cleaner or citrus-based degreaser. **DO NOT** use chlorine-based solvents such as brake parts cleaner or acetone—if you happen to splash some onto a painted surface, you will ruin the finish.

	<p>⚠ WARNING NEVER clean with gasoline or other petroleum-based solvents. Most have low flash points, which make them extremely flammable. A risk of explosion and burning exists if these products are used. Serious personal injury may occur if this warning is ignored!</p>
--	--

SETUP

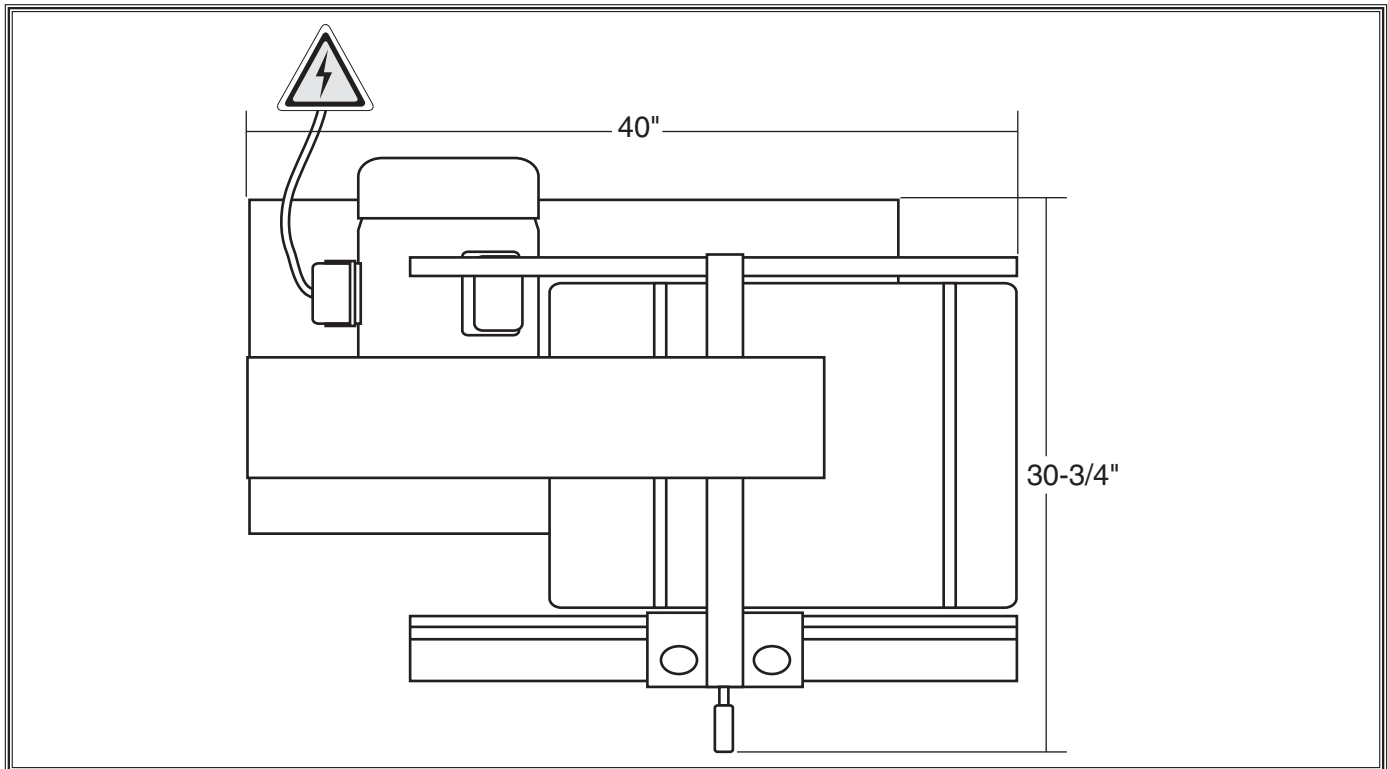

Figure 4. Model M1113 working clearances.

Lifting & Moving

Lifting and moving this bandsaw is most safely done using a forklift. The upper frame is angled at the lifting area, so we recommend making a lifting block, as shown in **Figure 5**, to balance the machine when lifting.

If using a forklift is not an option, then the machine can be moved with a heavy-duty dolly and at least three strong people. Heavy-duty dollies can be easily purchased at your local hardware store or rented.

To lift and move the bandsaw with a forklift, do these steps:

1. Make the lifting block shown in **Figure xx** to ensure that the machine remains balanced when lifted and does not swing.
2. Place the lifting block under the upper frame, as shown in **Figure 6**.
3. Either place the forks directly against the lifting block, or place straps under the lifting block and around the upper frame.

Note: If you are using lifting straps, you must remove the blade and upper wheel to avoid damaging the machine. The upper wheel is easily removed by removing the hex nut from the center and sliding the wheel off.

To lift and move the bandsaw with three strong people and a dolly, do these steps:

1. Carefully "walk" (pivot the bandsaw in alternating steps) off of the shipping pallet and onto the shop floor.
2. Place the dolly under the machine and move it into place, having two extra people steady the machine the entire time so that it does not tip over.

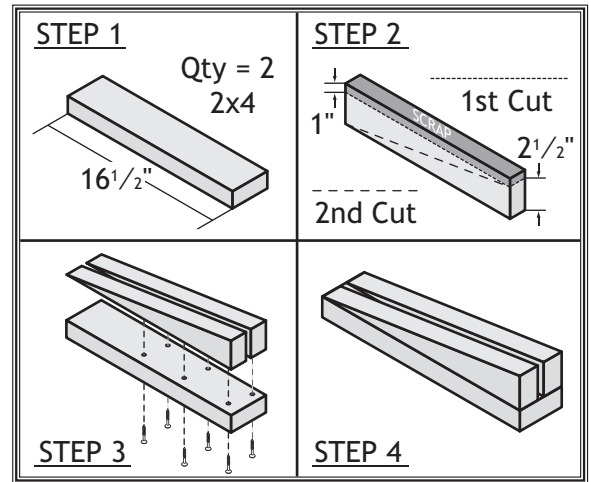

Figure 5. Making a lifting block.

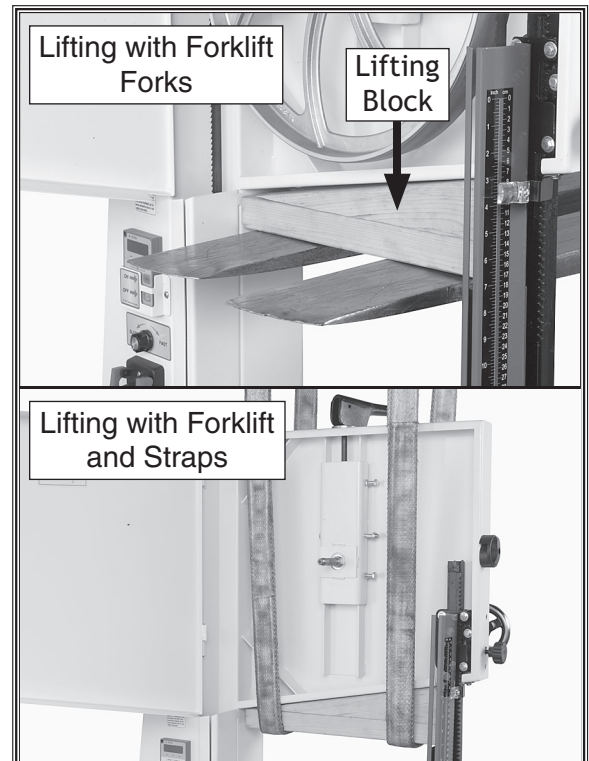

Figure 6. Lifting machine with a forklift.

! DANGER

This is a heavy machine that cannot be safely moved alone. Tipping this machine onto yourself or another person will cause serious personal injury. Use extreme caution when moving this machine without a forklift and only get help from strong, capable people.

SETUP

Mounting to Shop Floor

Although not required, we recommend that you mount your new machine to the floor. Because this is an optional step and floor materials may vary, floor mounting hardware is not included. Generally, you can either bolt your machine to the floor or mount it on machine mounts. Both options are described below. Whichever option you choose, it will be necessary to use a precision level to level your machine.

Bolting to Concrete Floors

Lag shield anchors with lag bolts and anchor studs (Figure 7) are two popular methods for anchoring an object to a concrete floor. We suggest you research the many options and methods for mounting your machine and choose the best that fits your specific application. Figure 8 shows the mounting locations for this machine.

NOTICE

Anchor studs are stronger and more permanent alternatives to lag shield anchors; however, they will stick out of the floor, which may cause a tripping hazard if you decide to move your machine at a later point.

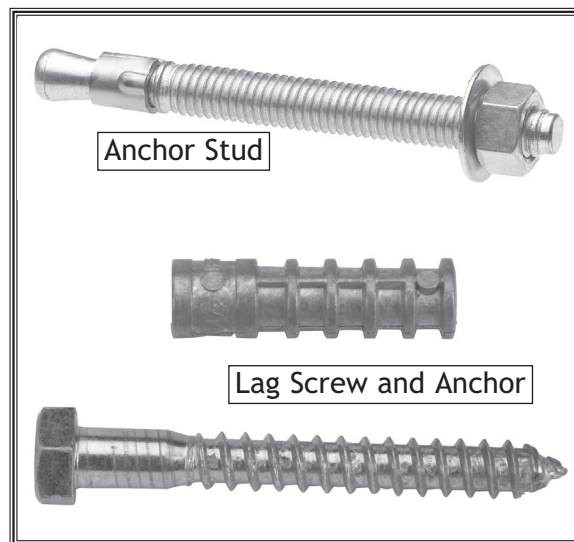

Figure 7. Typical fasteners for mounting to concrete floors.

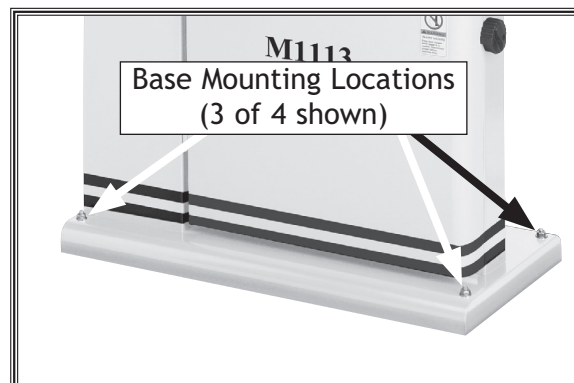

Figure 8. Location of machine base mounting locations.

Assembly

To assemble the bandsaw, do these steps:

1. Place the bandsaw table upside down on a flat surface (preferably a workbench) and make sure the table trunnion mounting bolts (Figure 9) are tight.
2. Attach the table extension to the table with the two $\frac{5}{16}$ -18 x 2" hex bolts, two $\frac{5}{16}$ -18 hex nuts, and four $\frac{5}{16}$ " flat washers, as shown in Figure 10. Make sure that the table and table extension are firmly pressed against the flat surface and tighten the bolts/nuts.
3. Remove the table pin from the table slot, fit the table around the blade, and rest the table trunnions on the trunnion base, making sure the trunnion bolts extend through the bottom of the trunnion base.
4. Thread the two table trunnion knobs onto the trunnion bolts, as illustrated in Figure 11.
5. Adjust the table stop bolt (Figure 12) so the table is approximately perpendicular to the blade. (Precise adjustment of the table stop bolt will be covered later.)
6. Place the table insert in the center of the table, so it sits flush with the table top surface.
7. Insert the table pin into the end of the table slot.

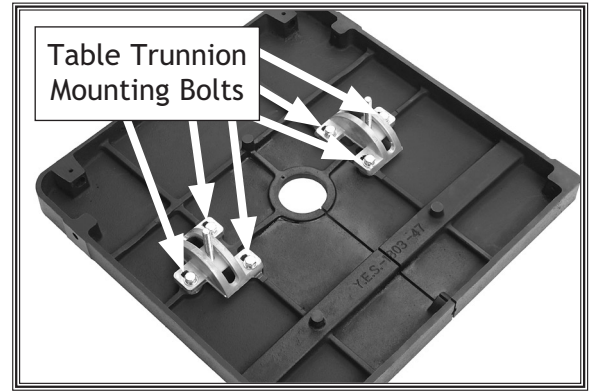

Figure 9. Table trunnion mounting bolts.

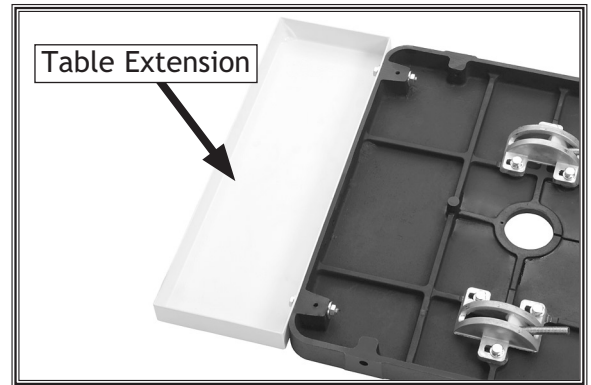

Figure 10. Table extension attached to table on flat surface.

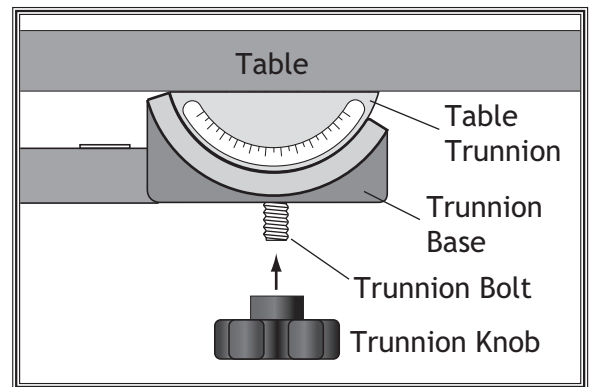

Figure 11. Installing the table on trunnion base.

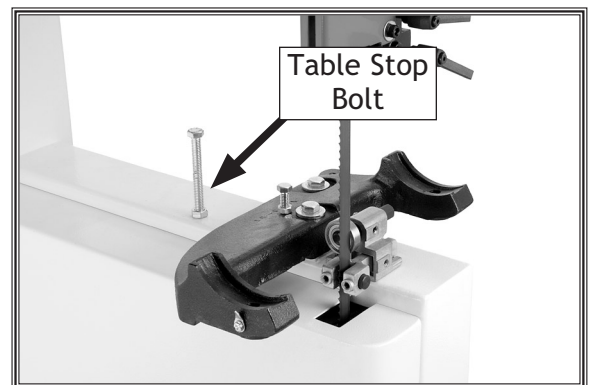

Figure 12. Table stop bolt.

SETUP

8. Attach the rear fence rail to the backside of the bandsaw table with two M6-1 x 6 cap screws, as shown in **Figure 13**.



Figure 13. Rear fence rail attached to table.

9. Attach the rail brackets to the front of the table with the two M6-1 x 16 cap screws, as shown in **Figure 14**.

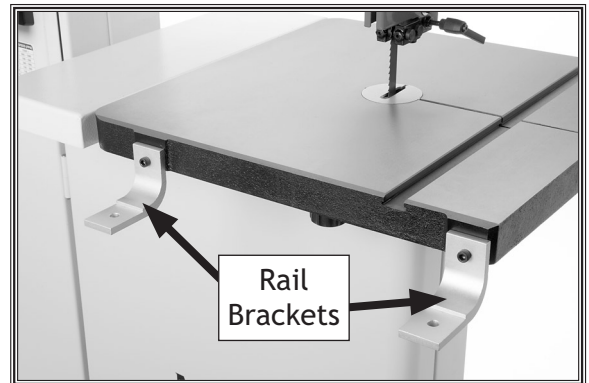

Figure 14. Rail brackets attached to table.

10. Insert the rail bracket knobs through the front fence rail brackets, then thread the T-nuts onto the ends of the knobs a couple of turns.
11. Slide the front fence rail T-slot over the T-nuts, as shown in **Figure 15**, then position the front fence rail brackets even with the rear fence rail, and tighten the knobs.

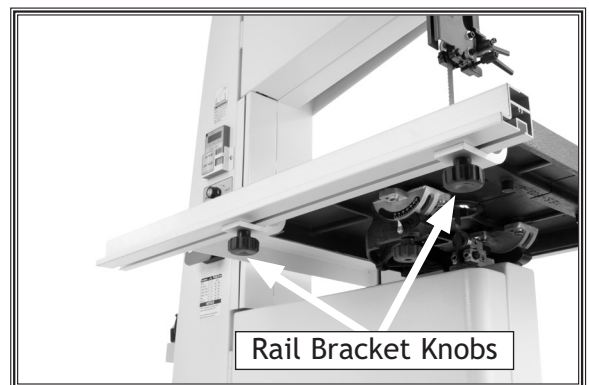

Figure 15. Front fence rail attached.

12. Pull the fence handle up and place the fence on the front fence rail, as shown in **Figure 16**.
13. Slide the fence against the blade.



Figure 16. Installing fence onto rails.

SETUP

14. Use a sharp pencil to mark the fence rail where the fence scale indicator on the right-hand side is pointing (there is a gap just behind the indicator plate where you can mark the rail). This mark will indicate where to align the 0" mark when you install the scale in Step 16.
15. Remove the fence from the front rail.
16. Carefully install the adhesive-backed scale on the front fence rail, as shown in **Figure 17**, so the 0" mark on the scale lines up with the pencil mark made in Step 14.
17. Insert the guide blocks into the upper and lower blade guide assemblies, making sure they are at least a 1/8" away from the blade (for now), then secure them with the six 1/4"-20 x 1/2" thumb screws, as shown in **Figure 18**.
18. Attach the miter gauge holder to the spine of the bandsaw, as shown in **Figure 19**, using the cap screws already installed in the bandsaw spine.
19. Insert the miter gauge in the holder holder, as shown in **Figure 19**.



Figure 17. Scale installed on front fence rail.

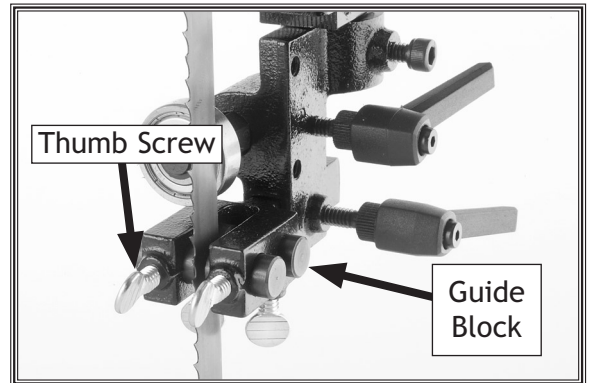

Figure 18. Blade guide installation.



Figure 19. Miter gauge holder attached with miter gauge inserted.

Dust Collection

Recommended CFM at each Dust Port: 400 CFM

Connect this machine to a shop vacuum rather than a dust collector. Most dust collectors are not designed to capture metal shavings and doing so may lead to a fire. If you are in doubt about the capabilities of your shop vacuum or dust collector, refer the owner's manual before connecting it to this machine.

CAUTION

This saw creates substantial amounts of fine dust while operating. Failure to use a vacuum system can result in respiratory illness.

CAUTION

ONLY connect this machine to a shop vacuum. A wood dust collector is not designed for metal chips, which may spark and cause a fire.



Figure 20. Dust port connected to dust collection system.

Blade Tracking

"Blade Tracking" is how and where the blade rides on the wheels. When tracking correctly, the blade rides on the peak of the wheel crowns. Blade tracking is primarily controlled by adjusting the upper wheel tilt, also known as "Center Tracking."

Another way to track the blade is known as "Coplanar Tracking." Coplanar tracking involves positioning the wheels so they are parallel and aligned (see **Wheel Alignment** on **Page 42**). When wheels are coplanar, vibration and heat are reduced during operation. The wheels on the Model M1113 are factory aligned, but should be checked to ensure optimum results.

To center track the blade:

1. DISCONNECT BANDSAW FROM POWER!
2. Adjust the upper/lower blade guides and support bearings away from the blade.
3. Open the upper wheel cover.
4. Rotate the blade tension lever to adjust the blade tension until the indicator on the blade tension scale matches the size of blade installed (see **Page 19**).
5. Spin the upper wheel by hand at least three times to see how the blade rides on the crown of the wheel. Refer to **Figure 21** for an illustration of this concept.
 - If the blade rides on the peak of the upper wheel crown, then the bandsaw is already tracked properly and no additional adjustments are needed. Skip to **Step 9**.
 - If the blade does not ride in the peak of the upper wheel crown, then continue with the next step.
6. Loosen the lock nuts on the blade tracking knob threads so the knobs will rotate for adjustments.
7. Spin the upper wheel with one hand and rotate the blade tracking knobs evenly with the other hand to make the blade ride on the center of the bandsaw wheel tire.
8. When the blade consistently rides on the center of the wheel, tighten the knob thread lock nuts.
9. Close the upper wheel cover.

NOTICE

Changes in the blade tension may change the blade tracking.

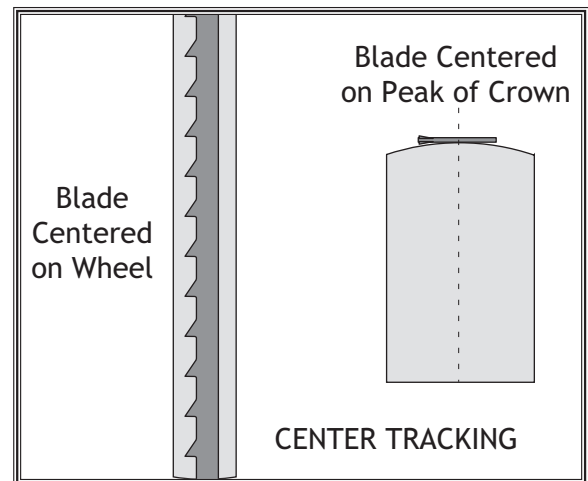

Figure 21. Center tracking profiles.

Test Run

Once the assembly is complete, test run the machine to make sure it runs properly for regular operations.

The test run consists of verifying the following: 1) The motor powers up and runs correctly, and 2) the safety disabling mechanism on the switch works correctly.

If, during the test run, you cannot easily locate the source of an unusual noise or vibration, stop using the machine immediately, then review **Troubleshooting** on **Page 46**. If you still cannot remedy a problem, contact our Tech Support at (360) 734-3482 for assistance.

To test run the machine, do these steps:

1. Connect the machine to the power source.
2. Make sure you understand the safety instructions at the beginning of the manual, and verify that the machine is setup properly.
3. Ensure all tools and objects used during setup are cleared away from the machine.
4. Press the green ON button on the power switch, then press the ON key on the motor switch to start the machine.
 - When operating correctly, the machine runs smoothly with little or vibration or rubbing noise.
 - Investigate and correct strange noises or vibrations before operating the machine further. Always disconnect the machine from power when investigating or correcting potential problems.
5. Turn the machine **OFF**.
6. Insert the switch disabling pin through the green ON button, as shown in **Figure 22**.
7. Press the ON button to test the disabling feature on the switch.
 - If the machine does not start, the switch disabling feature is working as designed.
 - If the machine starts, immediately stop the machine or disconnect the power. The switch disabling feature is not working correctly. Call Tech Support for help.

⚠ WARNING

Projectiles thrown from the machine could cause serious eye injury. Wear safety glasses to reduce the risk of injury.

⚠ WARNING

DO NOT investigate problems or adjust the machine while it is running. Wait until the machine is turned OFF, unplugged and all working parts have come to a complete stop before proceeding!

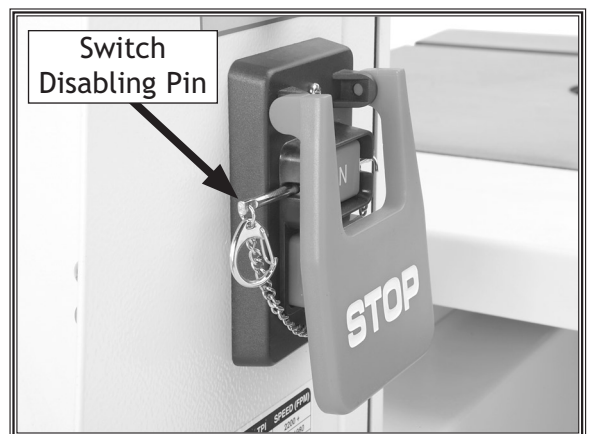

Figure 22. Switch disabling pin inserted into ON button.

SETUP

Blade Tensioning

A properly tensioned blade is essential for making accurate cuts and is a prerequisite for making many bandsaw adjustments. The blade tension is adjusted by rotating the blade tension lever.

To tension the bandsaw blade:

1. Make sure you have performed the **Test Run** instructions on the previous page and you are certain that the blade is tracking properly.
2. With the blade tension lever in the down (engaged) position, adjust the blade tension until the indicator on the blade tension scale (**Figure 23**) matches the size of blade installed on the bandsaw.

Note: *Because each blade is different and all blades stretch, this scale is only an approximation. Always measure blades from the tip of the tooth to the back of the blade.*

3. Turn the bandsaw **ON**.
4. Release the tension one quarter of a turn at a time. When the bandsaw blade starts to flutter, stop decreasing the tension.
5. Now, slowly increase the tension until the blade stops fluttering, then tighten the tension one more quarter of a turn.
6. Turn the bandsaw **OFF** and read the tension gauge. Use the reading as a guide when tensioning that blade in the future.

Note: *Do not rely on this measurement for long periods of time because the blade will stretch with use, making the tension gauge slightly inaccurate.*

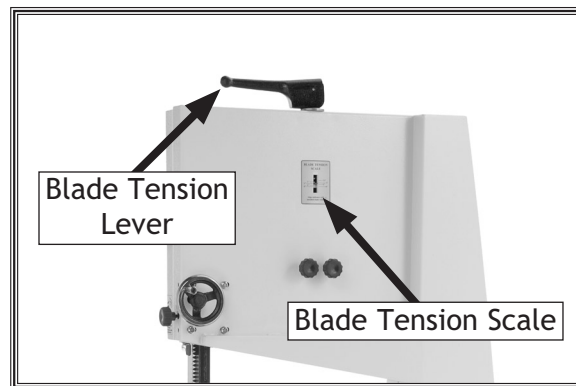

Figure 23. Blade tension scale.

NOTICE

To reduce blade stretching, remove the tension from the blade when not in use.

NOTICE

After blade tension and tracking are set correctly, properly adjust the upper/lower support bearings and guide-block assemblies into position before operating machine.

Support Bearing Adjustment

The support bearings are positioned behind the blade for support during cutting operations. Proper adjustment of the support bearings is an important part of making accurate cuts and also keeps the blade teeth from hitting the blade guides during cuts.

To adjust the support bearings, do these steps:

1. Make sure that the blade is tracking properly and that it is correctly tensioned.
2. DISCONNECT BANDSAW FROM POWER!
3. Familiarize yourself with the support bearing controls shown in **Figure 24**.
4. Remove the blade guard.
5. Loosen the cap screw shown in **Figure 24**.
6. Look at the face of the support bearing and rotate the blade guide assembly side-to-side, until the blade is perpendicular with the face of the support bearing, as illustrated in **Figure 25**.
7. Tighten the cap screw.
8. Loosen the lock lever on the support bearing adjustment shaft.
9. Position the support bearing approximately 0.016" away from the back of the blade as illustrated in **Figure 26**. To quickly gauge this setting, fold a dollar bill in half twice (when folded tightly, four thicknesses of a dollar bill is approximately 0.016"). Place the folded dollar bill between the support bearing and the blade as shown in **Figure 27**.
10. Tighten the lock lever to lock the support bearing in place.

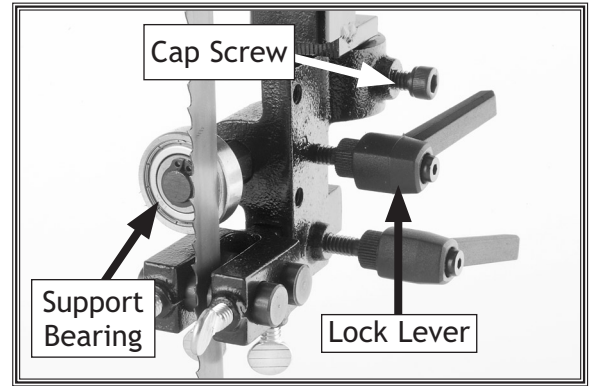

Figure 24. Support bearing controls.

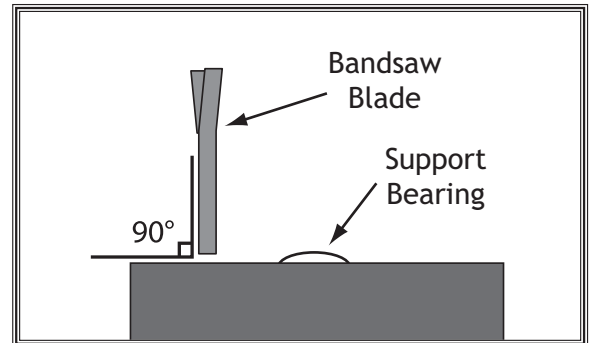

Figure 25. Blade should be perpendicular (90°) to the face of the support bearing.

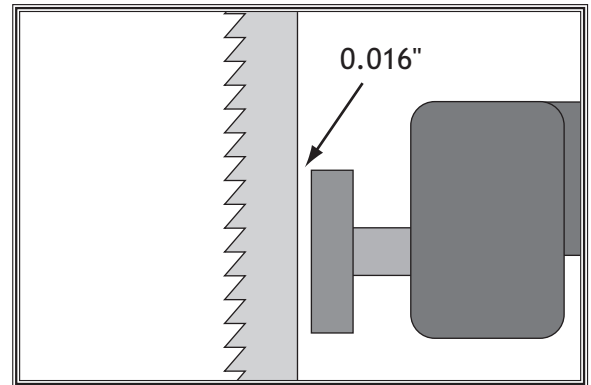

Figure 26. Blade should be aligned approximately 0.016" away from the bearing edge.

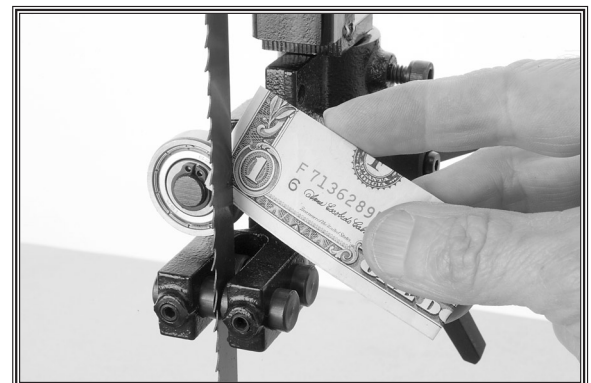

Figure 27. Dollar bill folded twice to make a quick 0.016" gauge.

NOTICE

Whenever changing a blade or adjusting tension and tracking, the upper and lower blade support bearings and guide-blocks must be re-adjusted before cutting operations.

Blade Guide Adjustment

The blade guides provide side-to-side support to help keep the blade straight while cutting. The blade guides adjust in two ways—forward/backward and side-to-side. Properly adjusted blade guides are essential to making accurate cuts.

To adjust the upper and lower blade guides, do these steps:

1. Make sure the blade tracks properly and is correctly tensioned.
2. DISCONNECT BANDSAW FROM POWER!
3. Familiarize yourself with the blade guide controls shown in **Figure 28**.
4. Loosen the lateral adjustment thumb screw.
5. Slide the guide assembly so the front edges of the blade guides are just behind the blade gullets as illustrated in **Figure 29**, then tighten the lateral adjustment thumb screw.

NOTICE

If the blade guides contact the blade teeth during operations, the tooth set on the blade will be ruined.

6. Loosen the blade guides.
7. Fold a crisp dollar bill in half and place it over the blade (between the blade guides and the blade), as shown in **Figure 30**.
8. Lightly pinch the dollar bill against the blade with the blade guides, then tighten the blade guide thumb screws.
9. Remove the dollar bill, then re-install the blade guard.

NOTICE

The blade guides should not touch the blade after the dollar bill is removed.

NOTICE

Whenever changing a blade or adjusting tension and tracking, the upper and lower blade guides and guide-blocks must be re-adjusted before cutting operations.

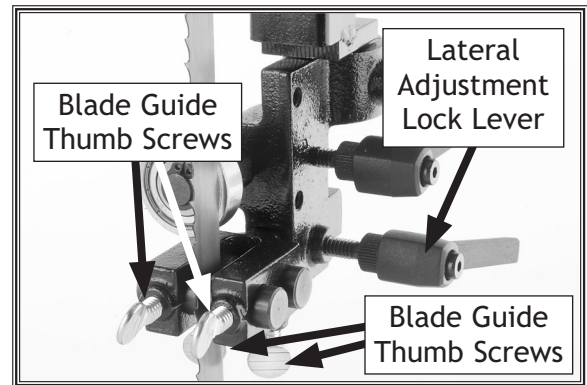

Figure 28. Blade guide controls.

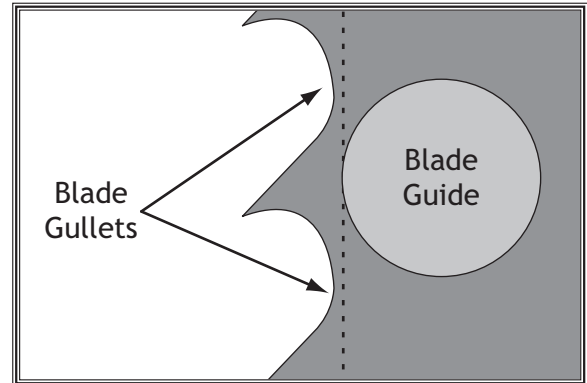

Figure 29. Lateral adjustment of blade guides.

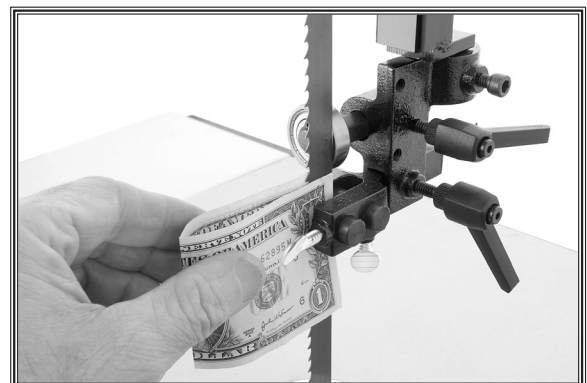

Figure 30. Blade guides against both sides of blade.

Table Stop Adjustment

An adjustable table stop allows the table to easily return to 90° after tilting.

To set the table stop so the table is 90° to the blade, do these steps:

1. Make sure the blade is correctly tensioned as described in the **Blade Tensioning** instructions on **Page 19**.
2. **DISCONNECT BANDSAW FROM POWER!**
3. Loosen the two table trunnion knobs.
4. Loosen the hex nut that locks the table stop bolt in place.
5. Raise the upper blade guide assembly and place a 6" machinist's square or try-square on the table next to the side of the blade as illustrated in **Figure 31**. Adjust the table stop bolt to raise or lower the table until the table is 90° to the blade.
6. Secure the knobs and lock the table stop bolt by tightening the hex nut against the casting. *Ensure that the bolt does not turn by holding it with another wrench while tightening the hex nut.*

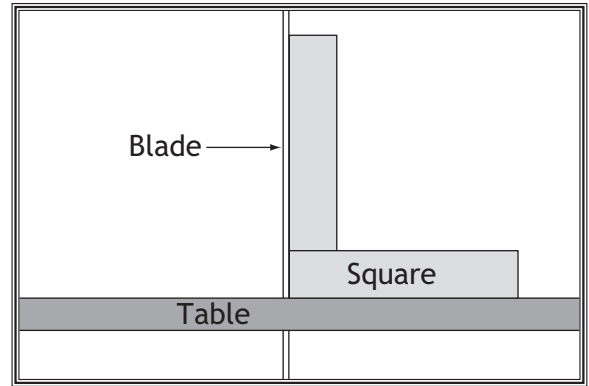

Figure 31. Squaring table to blade.

Table Tilt Scale Calibration

The pointer on the table tilt scale (**Figure 32**) must be calibrated in order for the scale reading to be accurate.

To calibrate the pointer on the table tilt scale, do these steps:

1. Make sure the blade is tensioned/tracking correctly and that the table is 90° to the blade (this procedure should be already completed with the **Table Stop Adjustment** instructions).
2. Loosen the pointer screw.
3. Align the tip of the pointer with the 0° mark on the table tilt scale.
4. Tighten the pointer screw.

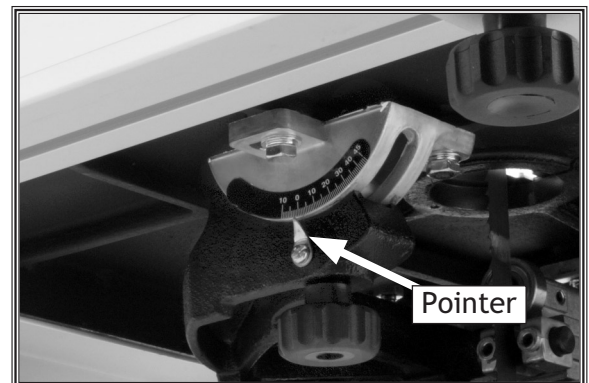

Figure 32. Table tilt scale.

Table Alignment

To ensure cutting accuracy when the table is first installed, align the table so the miter slot is parallel to the bandsaw blade. *This procedure works best with the largest blade that the machine accepts.*

To align the miter slot parallel to the bandsaw blade, do these steps:

1. Make sure the blade is correctly tracked and tensioned.
2. DISCONNECT BANDSAW FROM POWER!
3. Loosen the trunnion bolts that secure the trunnions to the table.
4. Place an accurate straightedge along the blade. The straightedge should lightly touch both the front and back of the blade (the flat part only) without touching the blade teeth.
5. Use a fine ruler to gauge the distance between the straightedge and the miter slot. The distance you measure should be the same at both the front and back ends of the miter slot, as indicated by positions "A" and "B" in Figure 33.
6. Adjust the table until the distance between the blade and miter slot is equal at both ends.
7. Tighten the trunnion bolts.

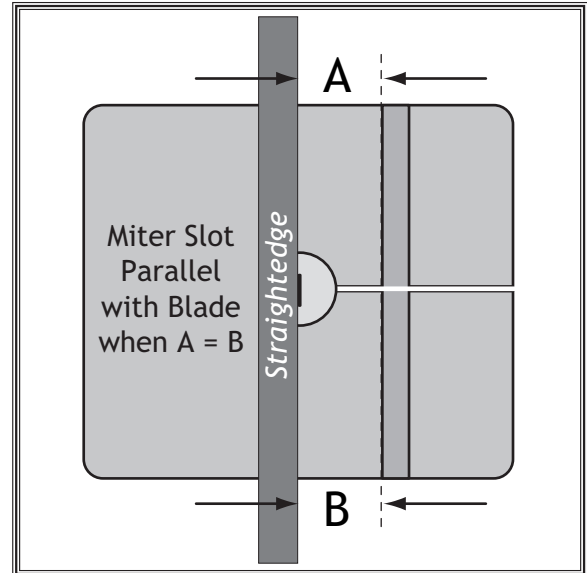

Figure 33. Checking if miter slot is parallel to blade.

Fence Alignment

To align the fence parallel with the miter slot, do these steps:

1. Mount the fence on the right-hand side of the blade, at the edge of the miter slot, then lock it in place.
2. Loosen the two cap screws that mount the front rail brackets to the table.
3. Shim between the front rail brackets and table to make the fence parallel with the miter slot.

Tip: Shim stock works well for this, but small pieces of paper can also work in a pinch.

4. Tighten the front rail mounting bolts.

NOTICE

Adjusting the fence parallel to the miter slot does not guarantee straight cuts. The miter slot may need to be adjusted parallel to the blade. Refer to the Table Alignment instructions.

OPERATIONS

General

This machine will perform many types of operations that are beyond the scope of this manual. Many of these operations can be dangerous or deadly if performed incorrectly.

The instructions in this section are written with the understanding that the operator has the necessary knowledge and skills to operate this machine. **If at any time you are experiencing difficulties performing any operation, stop using the machine!**

If you are an inexperienced operator, we strongly recommend that you read books, trade articles, or seek training from an experienced *bandsaw* operator before performing any unfamiliar operations. **Above all, your safety should come first!**

⚠ WARNING



READ and understand this entire instruction manual before using this machine. Serious personal injury may occur if safety and operational information is not understood and followed. DO NOT risk your safety by not reading!

Basic Controls

Motor Switch: Starts and stops the motor. Only works after the power switch has been reset and turned **ON**.

Speed Dial: Adjusts the speed of the motor, which is displayed in RPM on the digital display.

Power Switch: Turns power ON/OFF to the motor switch. OFF button must be reset (by pushing it all the way in) before power will turn **ON** again.

Blade Tension Lever: Increases/decreases blade tension when rotated. Quickly releases blade tension when pivoted up.

Blade Guide Elevation Handwheel: Raises/lowers the upper blade guide assembly when rotated. The blade guide assembly should always be no farther than 1" above the workpiece when cutting.

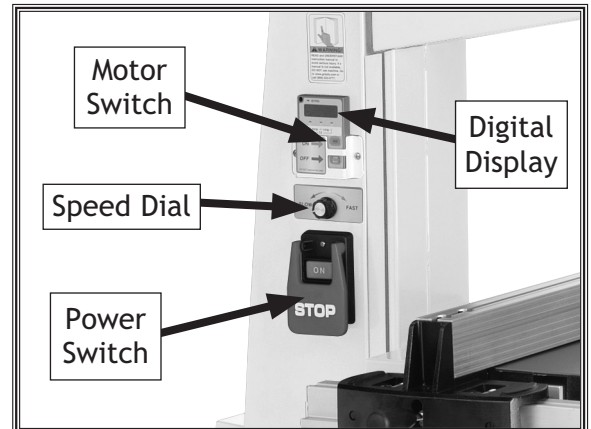

Figure 34. Motor, speed, and power controls.

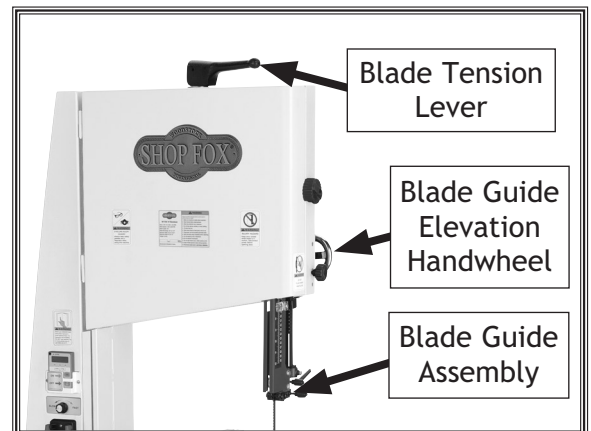

Figure 35. Blade tension/guide post controls.

Workpiece Inspection (Wood)

Some wood workpieces are not safe to cut or may require modification before they are safe to cut.

Before cutting wood, get in the habit of inspecting all workpieces for the following:

- **Foreign Objects (Figure 36):** Nails, staples, dirt, rocks and other foreign objects are often embedded in wood. While cutting, these objects can become dislodged and hit the operator or break the blade, which might then fly apart. Always visually inspect your workpiece for these items. If they can't be removed, do NOT cut the workpiece.
- **Large/Loose Knots:** Loose knots can become dislodged during the cutting operation. Large knots can cause blade damage. Choose workpieces that do not have large/loose knots or plan ahead to avoid cutting through them.
- **Wet or "Green" Stock:** Cutting wood with a moisture content over 20% causes unnecessary wear on the blade and yields poor results.
- **Excessive Warping:** Workpieces with excessive cupping, bowing, or twisting are dangerous to cut because they are unstable and can move unpredictably when being cut. DO NOT cut excessively warped wood.
- **Minor Warping:** Workpieces with slight cupping can be safely supported if the cupped side faces the table or fence, as shown in Figure 37. On the contrary, a workpiece supported on the bowed side will rock during a cut, leading to loss of control.

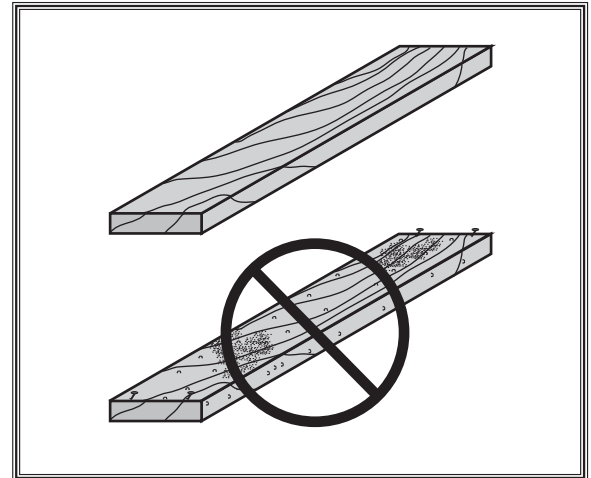

Figure 36. Choosing wood without embedded foreign objects embedded.

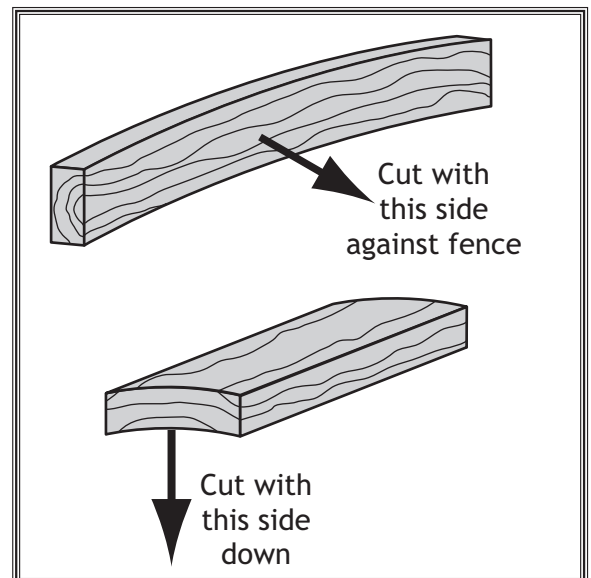

Figure 37. Cutting wood with minor warping.

WARNING

Because of its unpredictable nature, use extreme caution if cutting warped stock. The difference between acceptable and unacceptable warped stock varies from machine to machine. If you are in doubt, square-up the stock first or do not cut it.

Workpiece Inspection (Metal)

Some metal workpieces are not safe to cut with a vertical metal cutting bandsaw; instead, a different tool or machine should be used to do the cutting.

Before cutting, inspect the stock for any of the following conditions and take the necessary precautions:

- **Small or Thin Workpieces:** Small or thin workpieces are dangerous to cut if held by hand—avoid cutting these workpieces possible. If you must cut a small or thin workpiece, attach it to or clamp it between larger scrap pieces that will both support the workpiece through the cut and keep your fingers away from the blade. Some thin sheet metals will not withstand the forces from this bandsaw during cutting; instead, use a shear, nibblers, or sheet metal nippers to cut these pieces.
- **Round or Unstable Workpieces:** Workpieces that cannot be properly supported or stabilized without a vise should not be cut on a vertical metal-cutting bandsaw. Examples are chains, cables, round or oblong-shaped workpieces, workpieces with internal or built-in moving or rotating parts, etc.
- **Material Hardness:** Always factor in the hardness of the any metal before cutting it. Hardened metals will take longer to cut, may require lubrication, and may require a different type of blade in order to efficiently cut them.
- **Tanks, Cylinders, Containers, Valves, Etc:** Cutting into containers that are pressurized or contain gasses or liquids can cause explosions, fires, caustic burns, or machine damage. Avoid cutting any of these types of containers unless you have verified that the container is empty and it can be properly supported during a cut.
- **Magnesium:** Pure magnesium burns easily. Cutting magnesium with a dull blade can create enough friction to ignite the small magnesium chips into a fire. Avoid cutting magnesium if possible.
- **Beryllium:** Beryllium dust is toxic. Always wear a respirator when cutting Beryllium or any alloys containing Beryllium. Also wear the respirator when cleaning Beryllium dust and chips from the cutting area.

Cutting Overview

The bandsaw is capable of performing the following cuts:

- Miters
- Angles
- Compound Angles
- Resawing
- Ripping
- Crosscutting
- Simple and Complex Curves
- Duplicate Parts
- Circles
- Beveled Curves

Basic Cutting Tips

- Keep the upper blade guide assembly adjusted to within 1" of the workpiece.
- Replace, sharpen, and clean blades as necessary. Make adjustments periodically to keep the saw running in top condition.
- Use light and even pressure while cutting. Light contact with the blade makes it easier to follow lines and prevents extra friction, which reduces blade life.
- Avoid twisting the blade when cutting around tight corners. Allow the blade to saw around the corners.
- Misusing the saw or using incorrect techniques is unsafe and results in poor cuts. Remember—the blade does the cutting with the operator's guidance.
- Do not start the machine with the workpiece touching the blade.
- When cutting metal, pay attention to the characteristics of the chips when cutting—they are good indicators of proper blade speed and feed rate. **Figure 38** shows the basic metal chip characteristics and what they mean.

Table Tilt

To tilt the table, do these steps:

1. Loosen the two trunnion knobs underneath the table.
2. Tilt the table to the desired angle. (Refer to the angle gauge on the front table trunnion.)
3. Retighten both table-tunnion knobs.

WARNING

ELECTROCUTION HAZARD

This bandsaw is not designed to be used with water soluble cutting fluid or coolant when cutting metals. Instead, use a small amount of oil-based lubricant.

Chips are width of tooth, thin, curled, and silvery:
Optimum speed and feed rate.

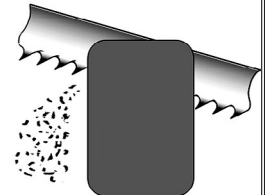

Chips are silvery, thin, small, or powdery: Increase feed rate; decrease blade speed.

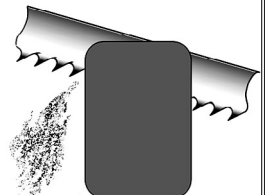

Chips are large, curled, blue or brown, or smoking:
Decrease feed rate; increase blade speed.

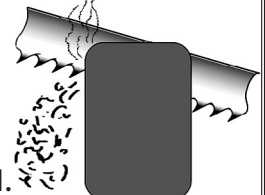

Figure 38. Reading metal chip characteristics.

NOTICE

The table stop must be removed to tilt the table left of 0°.

Guide Post

The guide post (shown in **Figure 39**) connects the upper blade guide assembly to the bandsaw. The guidepost allows the blade guide assembly to move up or down to be as close to the workpiece as possible. In order to cut accurately and safely, the bottom of the blade guide assembly must be no more than 1" above the workpiece at all times—this positioning provides the greatest blade support and minimizes the amount of moving blade exposed to the operator.

To adjust the blade guide assembly on the guide post (the bandsaw must be turned OFF), do these steps:

1. Make sure that the blade tension, blade tracking, support bearing, and blade guides are adjusted correctly.
2. Loosen the guide post lock knob shown in **Figure 39**.
3. Use the guide post handwheel to raise/lower the guide post so the bottom of the blade guide assembly is less than 1" from the top of the workpiece.
4. Lock the guide post with the lock knob.

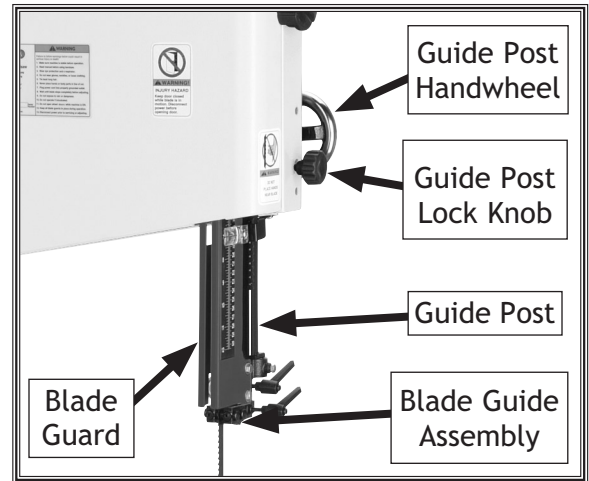

Figure 39. Guide post controls.

Rip Cutting

When cutting solid wood, "Rip Cutting" means cutting with the grain. For plywood or metal, rip cutting simply means cutting down the length of the workpiece.

To make a rip cut, do these steps:

1. Adjust the fence to match the width of the cut on your workpiece, then lock the fence in place.
2. Adjust the blade guide assembly to less than 1" above the workpiece.
3. After all safety precautions have been met, turn the bandsaw **ON**. Slowly feed the workpiece into the blade and continue with the cut until the blade is completely through the workpiece. **Figure 40** shows a typical ripping operation.

Note: If you cut narrow pieces, use a push stick to protect your fingers.



Figure 40. Typical rip cut.

WARNING

NEVER place fingers or hands in the line of cut. If you slip, your hands or fingers may go into the blade. **ALWAYS** use a push stick when ripping narrow pieces. Failure to follow these warnings may result in serious personal injury!

Crosscutting

"Crosscutting" means cutting across the grain of wood. For plywood or metal, crosscutting simply means cutting across the width of the workpiece.

To make a 90° crosscut, do these steps:

1. Move the fence out of the way, adjust the blade guide assembly to to less than 1" above the workpiece, and make sure the miter gauge is set to 90°.
2. Mark the workpiece on the edge where you want to begin the cut, place the workpiece evenly against the miter gauge, and align the mark with the blade.
3. After all safety precautions have been met, turn the bandsaw **ON**. Slowly feed the workpiece into the blade and continue the cut until the blade is all the way through the workpiece. **Figure 41** shows a typical crosscutting operation.



Figure 41. Typical crosscutting operation.

Resawing

"Resawing" (**Figure 42**) is cutting a workpiece into two or more thinner workpieces. Use the widest blade possible when resawing—a wide blade cuts straighter and is less prone to blade lead (see **Page 40**). For most applications, use a blade with a hook- or skip-tooth style. Choose blades with fewer teeth-per-inch (from 3 to 6), because they offer larger gullet capacities for clearing sawdust, reducing heat buildup and reducing strain on the motor.

To resaw a workpiece, do these steps:

1. Verify that the bandsaw is setup properly and that the table is perpendicular to the blade.
2. Use the widest blade your bandsaw will accept. **Note:** *The blade must also be sharp and clean.*
3. Adjust the fence to the desired width of cut, and lock it in place. (Support the ends of the board if necessary.)
4. Turn the bandsaw **ON**.
5. Using push paddles and a push stick, maintain workpiece pressure against the fence and table, and slowly feed the workpiece into the moving blade until the blade is completely through the workpiece (see **Figure 42**).

⚠ WARNING

Because of its unpredictable nature, use extreme caution if cutting warped stock. The difference between acceptable and unacceptable warped stock varies from machine to machine. If you are in doubt, square-up the stock first or do not cut it.

NOTICE

The scale on the front rail will NOT be accurate when using the resaw fence.

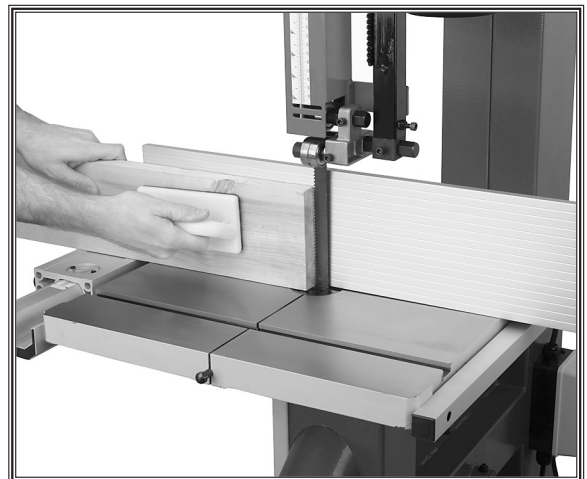

Figure 42. Typical resawing operation.

Cutting Curves

When cutting curves, simultaneously feed and turn the stock carefully so the blade follows the layout line without twisting. If a curve is so abrupt that it is necessary to repeatedly back up and cut a new kerf, use a narrower blade, a blade with more TPI (teeth per inch), or make more relief cuts.

Relief cuts are made through the waste portion of the workpiece and stop at the layout line. Relief cuts reduce the chance that the blade will be pinched or twisted during the cut.

Stacked Cuts

One of the benefits of a bandsaw is its ability to cut multiple copies of a particular shape by stacking workpieces together and cutting them as one. Before making stacked cuts, ensure that both the table and the blade are properly adjusted to 90°; otherwise, any error will be compounded.

To complete a stacked cut, do these steps:

1. Align your pieces from top-to-bottom to ensure that each piece has adequate scrap to provide a clean, unhampered cut.
2. Secure all the pieces together in a manner that will not interfere with the cutting. For wood, hot glue on the edges works well, as do brad nails through the waste portion. (Be careful not to cut into the brads or you may break the blade!)
3. On the face of the top piece, mark the shape you intend to cut.
4. Make relief cuts perpendicular to the outline of your intended shape in areas where changes in blade direction could cause the blade to bind.
5. Cut the stack of pieces as though you were cutting a single piece. Follow your layout line with the blade kerf on the waste side of your line as shown in **Figure 44**.

The list below shows the minimum radius that can be cut by common blade widths.

Width	Radius
1/8"	1/8"
3/16"	3/8"
1/4"	5/8"
3/8"	1 1/4"
1/2"	2 1/2"
5/8"	3 3/4"
3/4"	5 1/2"

Figure 43. Blade width radii.

OPERATIONS

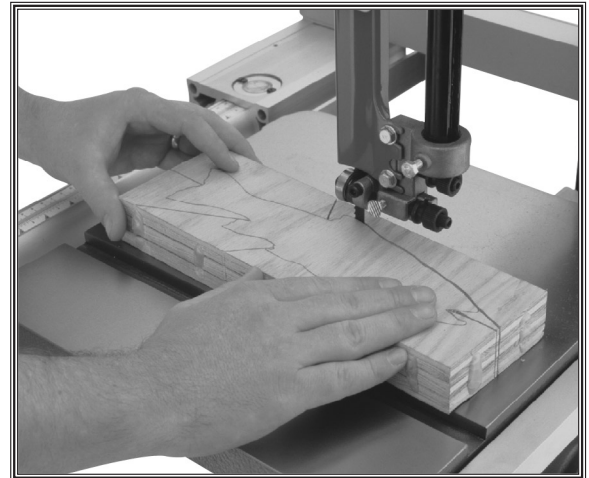

Figure 44. Typical stacked cut.

Blade Characteristics (Wood Cutting)

Blade Length

Measured by the circumference, blade lengths are usually unique to the brand of your bandsaw and the distance between wheels. This saw uses 133" long blades.

Blade Width

Measured from the back of the blade to the tip of the blade tooth (the widest point), blade width is often the first consideration given to blade selection. Blade width dictates the largest and smallest curve that can be cut, as well as how accurately it can cut a straight line.

This saw uses blades from $\frac{1}{8}$ " to $1\frac{1}{4}$ " in width. Always pick the size of blade that best suits your application.

- **Curve Cutting:** Use the chart in **Figure 43** to determine the correct blade for curve cutting. Determine the smallest radius curve that will be cut on your workpiece and use the corresponding blade width.
- **Straight Cutting:** Use the largest width blade that you own. Large blades excel at cutting straight lines and are less prone to wander.

Tooth Style

Figure 45 illustrates the three main tooth styles:

- **Raker:** Considered to be the standard because the tooth size and shape are the same as the tooth gullet. The teeth on raker blades usually are very numerous, have no angle, and produce cuts by scraping the material; these characteristics result in very smooth cuts, but do not cut fast and generate more heat than other types while cutting.
- **Skip:** Similar to a raker blade that is missing every other tooth. Because of the design, skip toothed blades have a much larger gullet than raker blades, and therefore, cut faster and generate less heat. However, these blades also leave a rougher cut than raker blades.
- **Hook:** The teeth have a positive angle (downward) which makes them dig into the material, and the gullets are usually rounded for easier waste removal. These blades are excellent for the tough demands of resawing and ripping thick material.

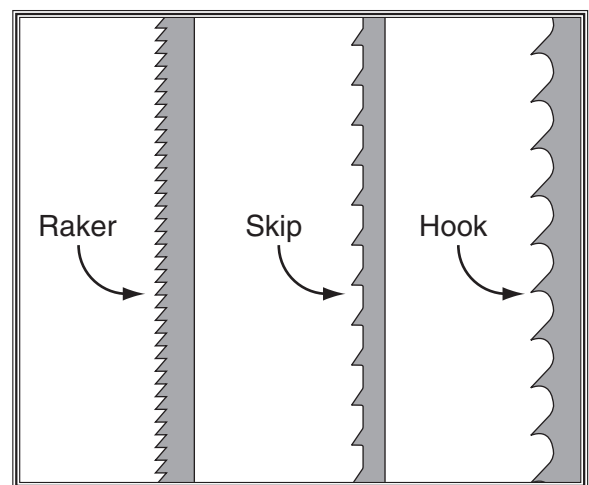

Figure 45. Raker, Skip & Hook tooth styles.

TOOTH PITCH

Usually measured as TPI (teeth per inch), tooth pitch determines the size/number of the teeth. More teeth per inch (fine pitch) will cut slower, but smoother; while fewer teeth per inch (coarse pitch) will cut rougher, but faster. As a general rule, choose blades that will have at least three teeth in the material at all times. Use fine pitched blades on harder woods and coarse pitched blades on softer woods.

BLADE CARE

A bandsaw blade is a delicate piece of steel that is subjected to tremendous strain. You can obtain longer use from a bandsaw blade if you give it fair treatment and always use the appropriate feed rate for your operation. Be sure to select blades with the proper width, style, and pitch for each application. The wrong choice of blades will often produce unnecessary heat which will shorten the life of your blade.

A clean blade will perform much better than a dirty blade. Dirty or gummed up blades pass through the cutting material with much more resistance than clean blades. This extra resistance also causes unnecessary heat. Resin/pitch dissolving cleaners are excellent for cleaning dirty blades.

BLADE BREAKAGE

Many conditions may cause a bandsaw blade to break. Blade breakage is unavoidable, in some cases, since it is the natural result of the peculiar stresses that bandsaw blades must endure. Blade breakage is also due to avoidable circumstances. Avoidable breakage is most often the result of poor care or judgement on the part of the operator when mounting or adjusting the blade or support guides.

The most common causes of blade breakage are:

- Faulty alignment/adjustment of the guides.
- Forcing/twisting a wide blade around a short radius.
- Feeding the workpiece too fast.
- Dull teeth or damaged tooth set.
- Overtensioned blade.
- Top blade guide assembly set too high above the workpiece.
- Using a blade with a lumpy or improperly finished braze or weld.
- Continuously running the bandsaw when not in use.
- Leaving blade tensioned when not in use.
- Using the wrong TPI for the workpiece thickness. (The general rule of thumb is three teeth in the workpiece at all times.)

Blade Selection (Metal Cutting)

Selecting the right blade for the job depends on a variety of factors, such as the type of material being cut, hardness of the material, material shape machine capability, and operator technique.

The chart below is a basic starting point for choosing a blade type based on teeth per inch (TPI) for variable tooth pitch blades and for standard raker type bi-metal blades/HSS blades. However, for exact specifications of bandsaw blades, contact the blade manufacturer.

To select the correct blade TPI, do these steps:

1. Measure the material thickness.

2. Refer to the "Material Width/Diameter" row of the blade selection chart in **Figure 46** and read across to find the workpiece thickness you need to cut.
3. Compare the "Material Shapes" row to the material to be cut.
4. In the applicable row, read across to the right and find the box where the row and column intersect. Listed in the box is the minimum TPI recommended for the variable tooth pitch blades.
5. The "Cutting Speed Rate Recommendation" section of the charts offers guidelines for various metals, given in feet per minute (speed FPM) and meters per minute in parenthesis. Choose the speed closest to the number shown in the chart.

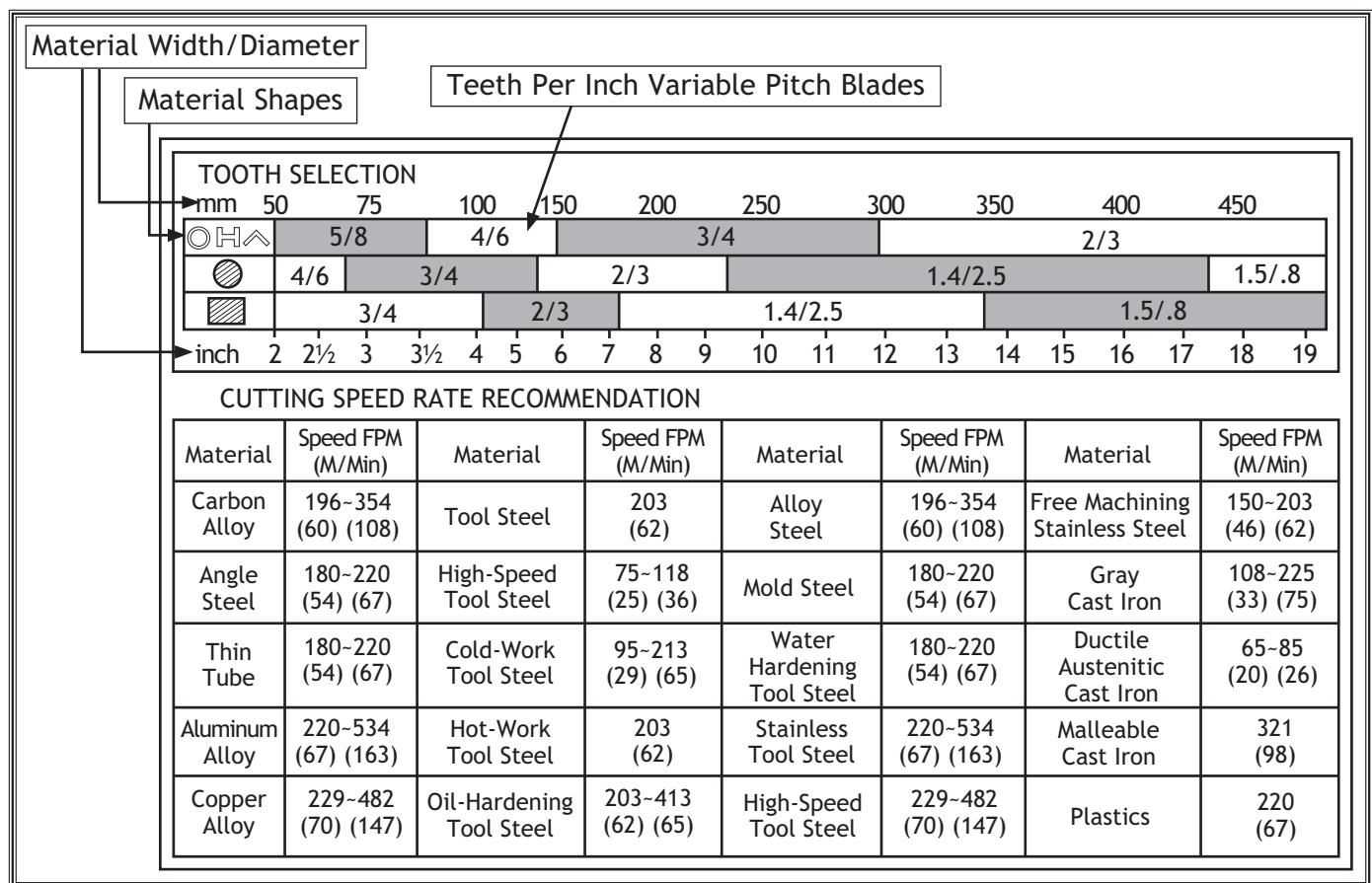

Figure 46. Blade selection and speed chart.

OPERATIONS

Blade Changes

To replace the blade, do these steps:

1. DISCONNECT BANDSAW FROM POWER!
2. Release the tension lever.
3. Remove the table insert and the table pin. Adjust the upper and lower guide blocks away from the blade.
4. Open the upper and lower wheel covers and slide the blade off both wheels.
5. Rotate the blade 90° and slide it through the slot in the table.
6. Slide the new blade through the table slot, ensuring that the teeth are pointing down toward the table. *If the teeth will not point downward in any orientation, the blade is inside-out. Put on heavy gloves, remove the blade, and twist it rightside-out.*
7. Slip the blade through the guides, and mount it over the upper and lower wheels.
8. Apply tension.
9. Turn the tension knob until proper blade tension has been reached according to the blade thickness scale shown in **Figure 47**.
10. Check and adjust the tracking (**Page 17**).
11. Adjust the upper/lower guide blocks and the support bearings (**Pages 20 and 21**).
12. Close the wheel covers.
13. Replace the table insert and table pin, being sure not to use excessive force when inserting the table pin.

OPERATIONS

⚠ WARNING



Always disconnect power to the machine when changing blades. Failure to do this may result in serious personal injury.

⚠ CAUTION



All saw blades are dangerous and may cause personal injury. To reduce the risk of being injured, wear leather gloves when handling saw blades.

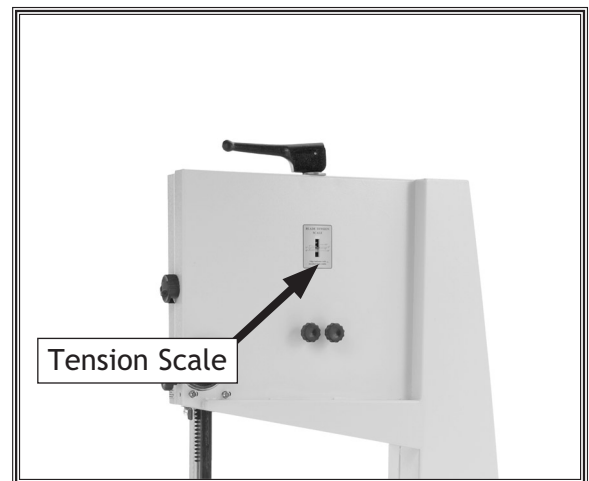

Figure 47. Tensioner adjustment.

Fence Scale Calibration

You may need to recalibrate the fence scale after changing or adjusting the blade, or if the scale is not producing accurate cuts. Recalibrate the fence scale by adjusting the hairline indicator on the fence and testing your adjustment by cutting a piece of scrap wood.

To calibrate the scale, do these steps:

1. Set the fence anywhere along the scale and locate a piece of scrap wood with at least one straight edge.

Note: Joint the edge with a jointer (if needed) to make the edge straight.

2. Hold the straight edge of the workpiece firmly against the fence, and feed the workpiece through the saw blade with a push stick.
3. Measure the width of the cut workpiece. The width of the workpiece should match the reading on the fence scale.
4. If the reading on the scale is not the same as the width of the cut workpiece, loosen the screw on the magnifying window (**Figure 48**), and adjust it to match the width of the cut workpiece.
5. Tighten the screw; the scale is now correctly calibrated.

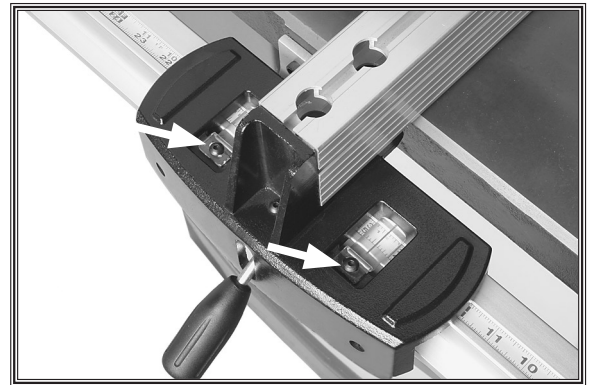
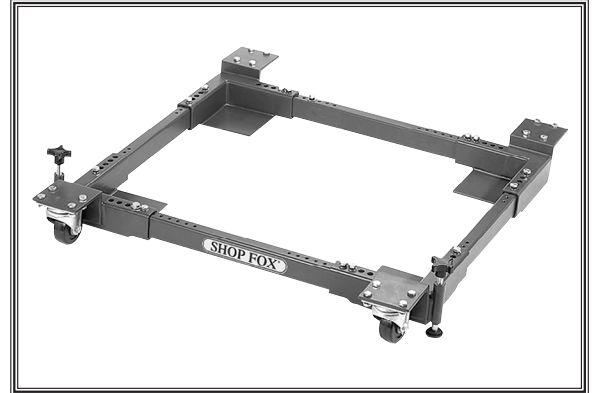

Figure 48. Scale calibration screws.

ACCESSORIES

The following accessories may be available through your local Woodstock International Inc. Dealer. If you do not have a dealer in your area, these products are also available through online dealers. Please call or e-mail Woodstock International Inc. Customer Service to get a current listing of dealers at: 1-800-545-8420 or at sales@woodstockint.com.

Model D2058 Shop Fox Super Heavy-Duty Mobile Base
Supports your machine so you can move it easily and lock it in place. Designed for long term and frequent moving of heavy machinery. All Shop Fox Adjustable Mobile Bases are strong enough to move heavy machines on a continual basis. The stands are adjustable to fit a variety of machines and can be leveled without the use of shims or tools.



Model W1054 Dust Collection Kit #1
Contains everything needed for a single machine hookup, including simple and concise instructions. Includes a 4" x 10' black plastic hose, a universal 4" dust hood, and two 4" wire hose clamps.



Model D3096 Shop Fox Featherboard
Reduce the risk of kickback and achieve consistent feeding results with these Shop Fox featherboards. Fits standard $\frac{3}{8}$ " x $\frac{3}{4}$ " miter gauge slots.

Model D3122 Shop Fox Push Stick
This essential safety item keeps hands at a safe distance from blades and cutters while still maintaining control of the workpiece against machine fences. A true necessity when running narrow stock. The durable handle is designed for maximum control. Measures $13\frac{1}{2}$ " overall. Super ergonomic design!

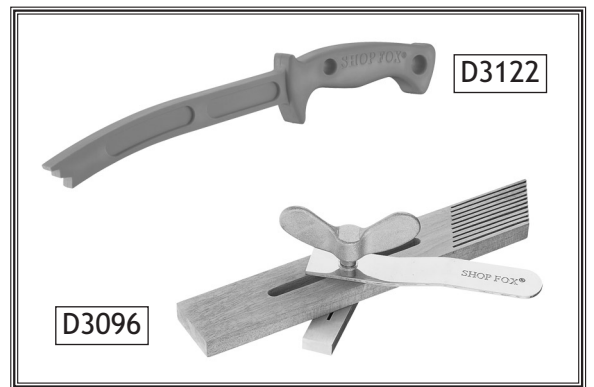

MAINTENANCE

Schedule

For optimum performance from your machine, follow this maintenance schedule:

Daily

- Check/correct loose mounting bolts.
- Check/correct damaged saw blade.
- Check/correct worn or damaged wires.
- Correct any other unsafe condition.

Monthly

- Check for V-belt tension, damage, or wear.
- Remove blade and thoroughly clean all built-up sawdust from the rubber tires on the wheels.
- Clean/vacuum dust buildup from inside cabinet and off motor.

Cleaning

Vacuum excess wood chips and sawdust, and wipe off the remaining dust with a dry cloth. If resin has built up, use a resin dissolving cleaner to remove it.

Once a month, remove the blade and thoroughly clean all built-up sawdust from the rubber tires on the wheels.

Table & Base

Protect the unpainted cast iron surfaces on the table by wiping the table clean after every use—this ensures moisture from wood dust does not remain on bare metal surfaces. Keep tables rust-free with regular applications of general lubricants such as G96® Gun Treatment, SLIPIT®, or Boeshield® T-9.

If the table becomes difficult to tilt, remove it and lubricate the trunnions and the slides in the trunnion base with a general lubricant.

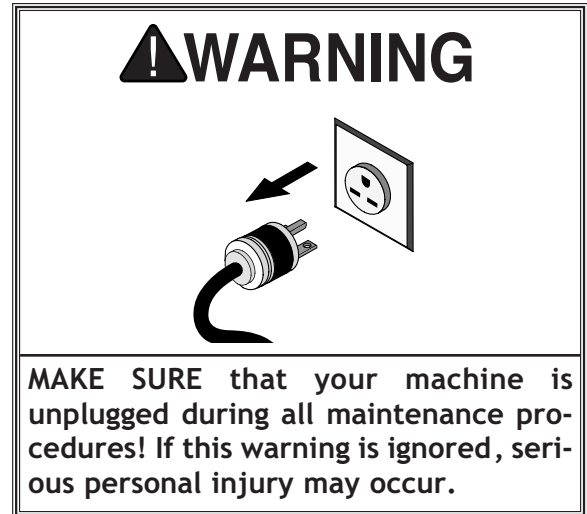

Redressing Rubber Tires

As the bandsaw ages, the rubber tires on the wheels may need to be redressed if they harden or glaze over. Redressing the rubber tires improves blade tracking and reduces vibration/blade lead.

If the rubber tires become too worn, then blade tracking will become extremely difficult. At that point, redressing will no longer be effective and the rubber tires must be replaced.

To redress the rubber tires, do these steps:

1. DISCONNECT BANDSAW FROM POWER!
2. Put on heavy leather gloves.
3. Remove the blade.
4. Clean any built-up sawdust from the rubber tires.
5. Hold 100 grit sandpaper against the rubber tire and rotate the wheel by hand. Only redress the rubber enough to expose a fresh rubber surface.

SERVICE

General

This section covers the most common service adjustments or procedures that may need to be made during the life of your machine.

If you require additional machine service not included in this section, please contact Woodstock International Technical Support at (360) 734-3482 or send e-mail to: tech-support@shopfox.biz.

Servicing V-Belts

To ensure optimum power transfer from the motor to the blade, the V-belts must be in good condition and operate under proper tension. Check belt tension at least every 3 months—more often if the bandsaw is used daily. V-belts stretch with use and must be periodically re-tensioned.

Accessing V-Belts

1. DISCONNECT BANDSAW FROM POWER!
2. Remove the bandsaw blade.
3. Remove the lower wheel by removing the hex bolt at the center of the wheel, then sliding the wheel off the shaft. (The hex nut has left handed threads, so you must turn it clockwise to loosen it.) You now have access to the V-belts for inspection or service (see Figure 49).

Checking V-Belts

1. Follow all previous instructions for **Accessing V-Belts**.
2. Push the center of each V-belt (Figure 50), using moderate force. Deflection should be about 1/4". If deflection is more than 1/4", tension that V-belt (Page 39) before doing Step 4.
3. Use a flashlight to inspect the belt. If a V-belt is cracked, frayed, or glazed, replace it soon.
4. Replace the pulley cover, lower wheel, and blade; then close the lower wheel cover.

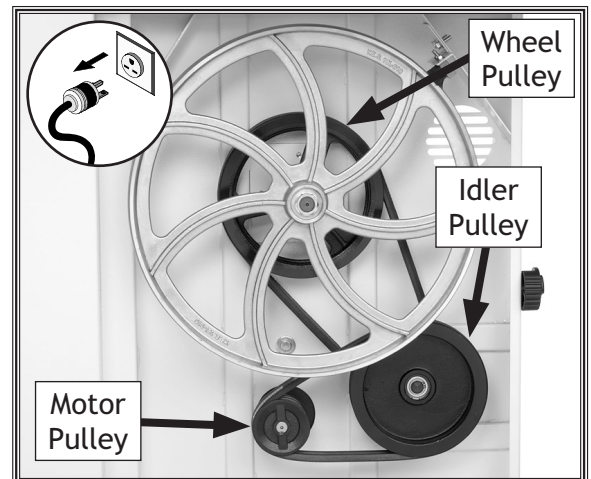
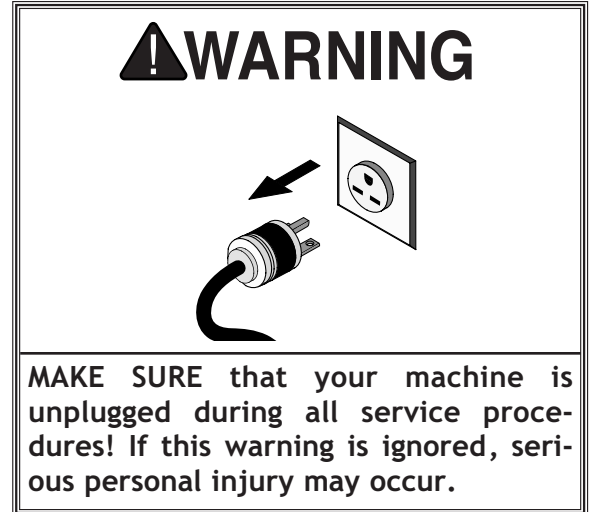

Figure 49. Pulleys and V-belts.

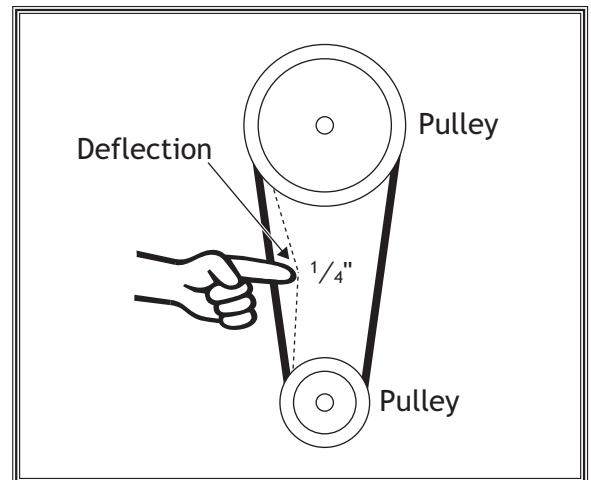

Figure 50. Belt deflection.

Tensioning/Replacing V-Belts

1. Follow all previous instructions for **Accessing V-Belts**.
2. Loosen the motor mount bolts shown in **Figure 51**.
3. Loosen the idler pulley mounting nut behind the cap shown in **Figure 52**.
 - If you only need to retension the V-belts, skip to **Step 6**.
 - If you need to replace the V-belts, continue with **Step 4**.
4. Pivot the motor and slide the idler pulley to loosen the V-belts.
5. Remove old V-belts and install the new V-belts.
6. Slide the idler pulley down to tighten the lower wheel V-belt, hold pressure on the idler pulley, then tighten the mounting nut.
7. Check the wheel pulley V-belt for correct tension. Retension if necessary before continuing.
8. Pivot the motor to tighten the motor V-belt, hold pressure on the motor, then tighten the motor adjustment bolt.
9. Check the motor V-belt for correct tension. Retension if necessary before continuing.
10. When the belt tension is correct, tighten the motor hinge bolt.
11. Replace the pulley cover, lower wheel, and blade; then close the lower wheel cover.

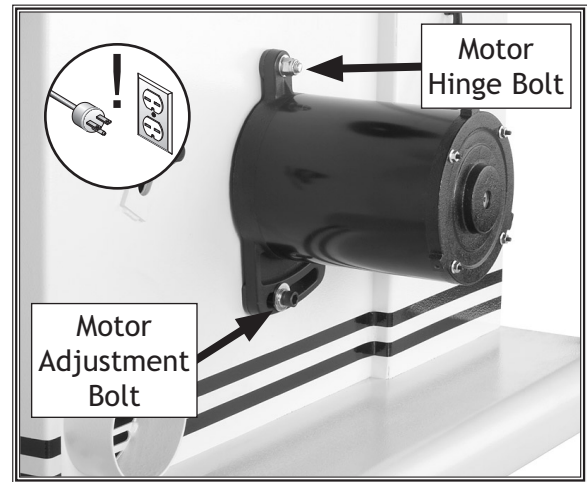

Figure 51. Motor mount bolts.

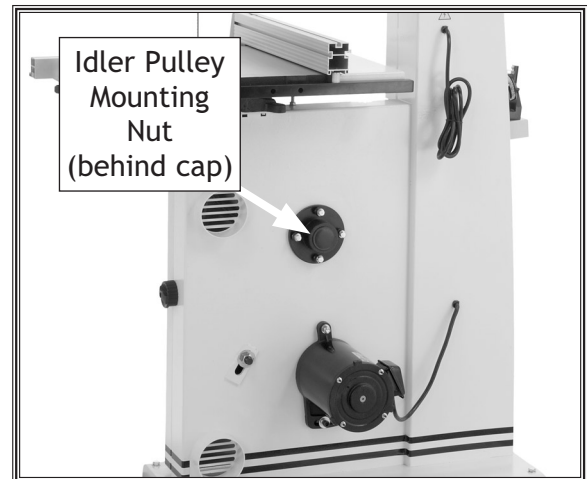

Figure 52. Location of idler pulley mounting nut.

Shimming Table

To ensure accuracy when cutting stacked workpieces, the table should be 90° to the back of the blade as shown in **Figure 53**. If the table is not perpendicular to the back of the blade, the table needs to be shimmed.

Shims can be made of any durable object that can be sandwiched between the table and the trunnions. We recommend using shim washers or shim stock because of the wide range of available thicknesses. These items can be purchased at your local hardware store.

To shim the table, do these steps:

1. Make sure that the blade is tracking properly and that it is correctly tensioned.
2. **DISCONNECT BANDSAW FROM POWER!**
3. Loosen the trunnion bolts that secure the trunnions to the table.
4. Shim between the table and the two trunnions to move the table in the desired direction.
5. Follow the **Aligning Table** instructions on **Page 23** to complete this procedure.

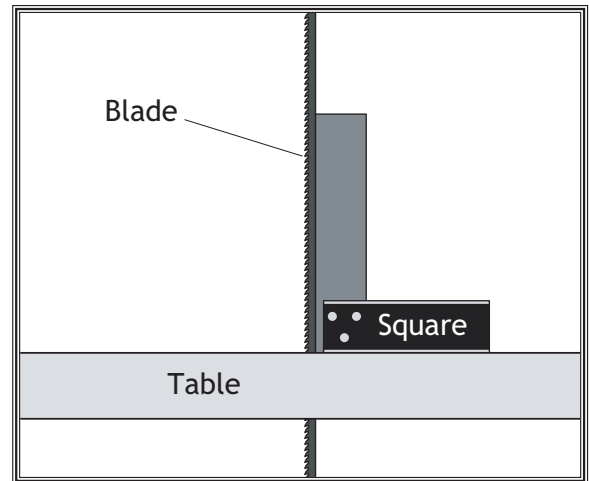

Figure 53. Squaring table to blade back.

Blade Lead

"Blade Lead" means that the blade does not cut straight when using the fence or miter gauge (see **Figure 54**). This is a common condition with all bandsaws. Worn or damaged blades may cause lead and replacing them will fix the problem. Still, if your bandsaw is setup correctly and lead occurs, compensate for it by skewing the fence.

To correct blade lead, do the following steps and make a test cut before skewing the fence:

1. Ensure that you have proper blade tension (refer to **Page 19**).
2. Ensure that the blade guides are adjusted correctly (refer to **Pages 20 & 21**).
3. Ensure that the miter slot or fence is parallel to the blade (refer to **Page 23**).

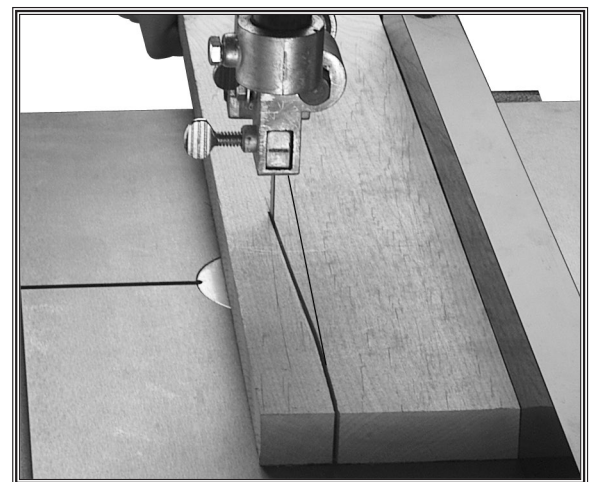

Figure 54. Blade leading away from line of cut.

To skew your fence, do these steps:

1. Cut a piece of scrap wood approximately $\frac{3}{4}$ " thick x 3" wide x 17" long. On a wide face of the board, draw a straight line parallel to the long edge.
2. Slide the fence out of the way and cut free-hand along the line. Stop at the halfway point. Turn the bandsaw **OFF** and wait for the blade to stop.
3. Clamp the board to the bandsaw table without moving it. Now slide the fence over to the board so it barely touches one end of the board.
4. Loosen the two cap screws that mount the front rail brackets to the table.
5. Shim between the front rail brackets and the table as necessary to make the fence parallel to the edge of the scrap piece.

To compensate for lead when making straight crosscuts with the miter gauge, do these steps:

1. Set the miter gauge to 90° and verify that the gauge body is square to the miter bar, using a 90° square.
2. On a scrap piece of wood, mark a line that is perpendicular to the front edge of the workpiece.
3. Starting where the line begins, cut the board by pushing it through the blade with the miter gauge.
4. Loosen the table trunnion mounting bolts, and shift the table to compensate for the blade lead.
5. Repeat **Steps 1 & 2** until the blade cuts straight when wood is pushed through with the miter gauge.

NOTICE

If the table is shifted, the fence will be affected since it is attached.

NOTICE

Lead adjustments will change when new blades are mounted on the saw.

Wheel Alignment

When wheels are aligned, or coplanar, the bandsaw cuts straighter, with much less vibration, heat, and blade wear because the blade is automatically balanced on the wheel. See **Figure 55** to better understand coplanarity.

If your bandsaw develops tracking problems that can't be fixed by adjusting the upper wheel tracking knobs, then check the wheel alignment before taking any other steps.

Verifying Upper/Lower Wheels are Coplanar

1. DISCONNECT BANDSAW FROM POWER!
2. With the blade on and properly tensioned, hold a straightedge or a self-made "coplanarity gauge" (**Figure 55**) close to the center of both wheels. Make sure the straightedge or gauge fully extends across the wheels as shown in **Figure 55**.
 - If the wheels are coplanar, the straightedge will evenly touch the top and bottom of both wheels.
 - If the wheels are not coplanar, place the straight-edge on the lower wheel first (ensuring that it touches both the top and bottom rim), then adjust the upper wheel tracking knob to make the upper wheel parallel with the lower wheel.
 - If the straightedge does not touch both wheels evenly, the upper wheel needs to be shimmed or the lower wheel needs to be adjusted.

Shimming Upper Wheel

1. DISCONNECT BANDSAW FROM POWER!
2. Make sure the top wheel is adjusted parallel with the bottom wheel.
3. With the straightedge touching both points of the wheel that does not need to be adjusted, measure the distance away from the incorrect wheel with a fine ruler (see **Figure 56**).
4. Remove the blade from the saw, then remove the wheel that needs to be shimmed.
5. Determine how many shim washers you need to compensate for the distance measured in **Step 3** and place them on the wheel shaft.
6. Replace the wheel, the original washers, and the securing nut.

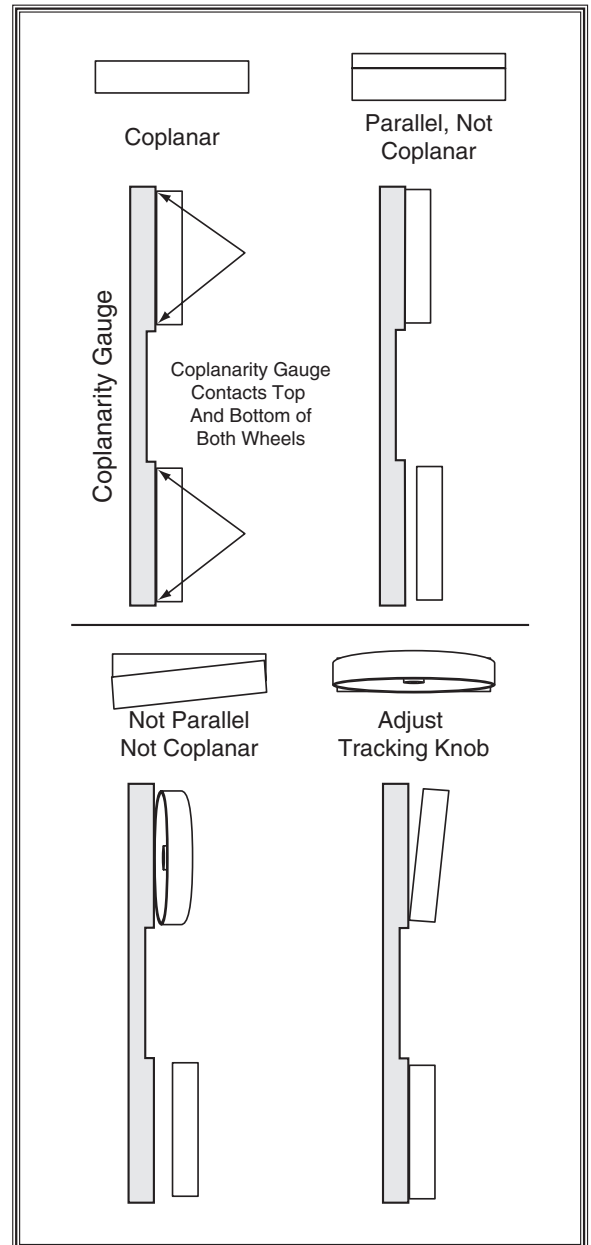

Figure 55. Coplanar diagram.

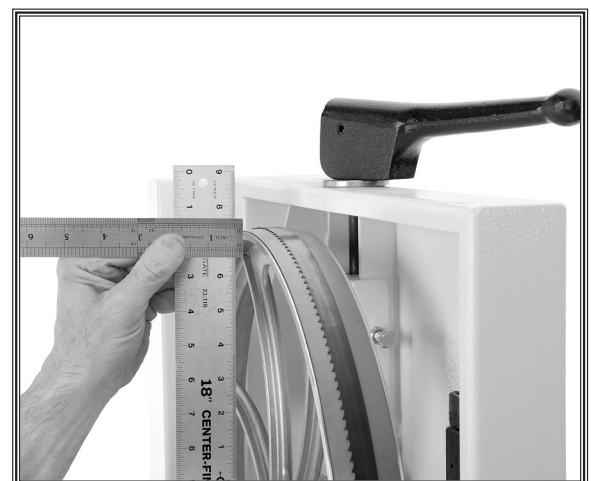

Figure 56. Measuring wheel difference.

7. Tighten the blade, then check the wheels. (Coplanar wheels may pull out of alignment when the blade is tightened.)
8. When the wheels are coplanar, place a mark on each wheel where you held the straightedge. This assures repeated accuracy every time you adjust your wheels.

Note: When wheels are properly coplanar, the blade may not be centered on the crown of the wheel, but it will be balanced.

Adjusting Lower Wheel

Only do this procedure if you cannot make the wheels coplanar with the tracking knob or by shimming the upper wheel. Make sure the upper wheel is adjusted as close as possible to being coplanar with the lower wheel before beginning. Do this procedure with the blade fully tensioned.

To adjust the lower wheel, do these steps:

1. DISCONNECT BANDSAW FROM POWER!
2. Loosen the four hex bolts on the lower wheel adjustment hub (Figure 57).
3. Rotate the wheel adjustment sleeves to tilt the lower wheel as necessary to make it coplanar with the upper wheel.
4. Tighten the hex bolts to lock the wheel adjustment sleeves in position.

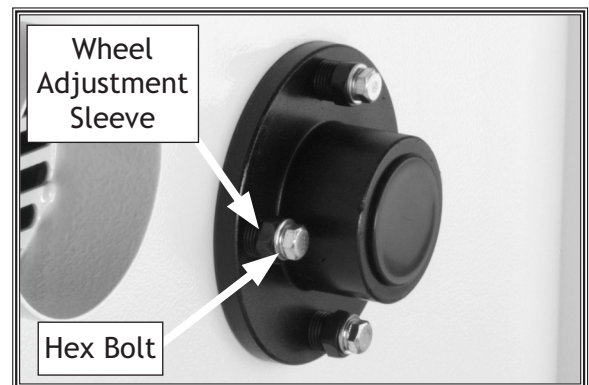

Figure 57. Wheel adjustment hub.

Electrical Component Wiring

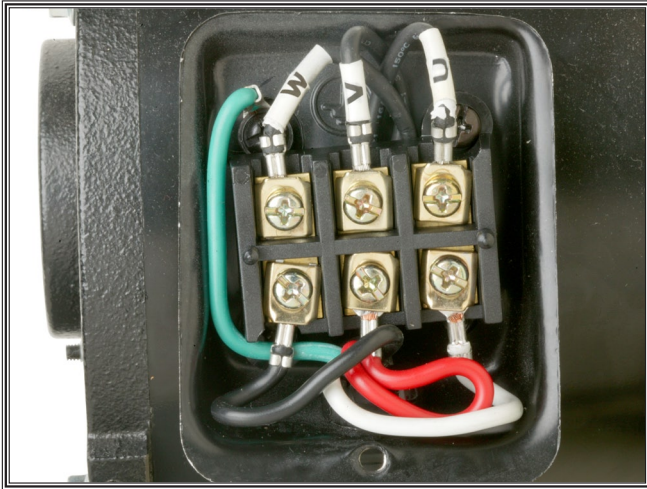

Figure 58. Motor junction box wiring.

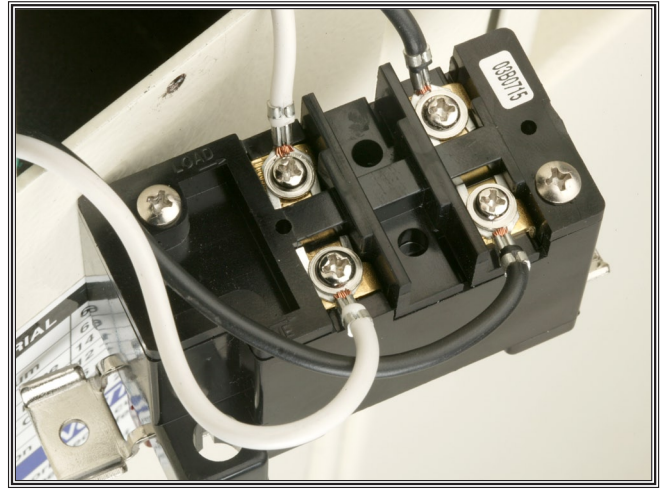

Figure 60. Power switch.



Figure 59. Motor switch.

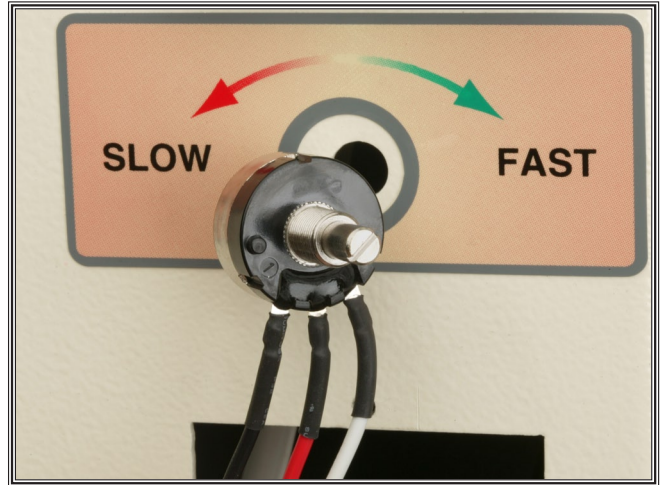

Figure 61. Variable speed dial.

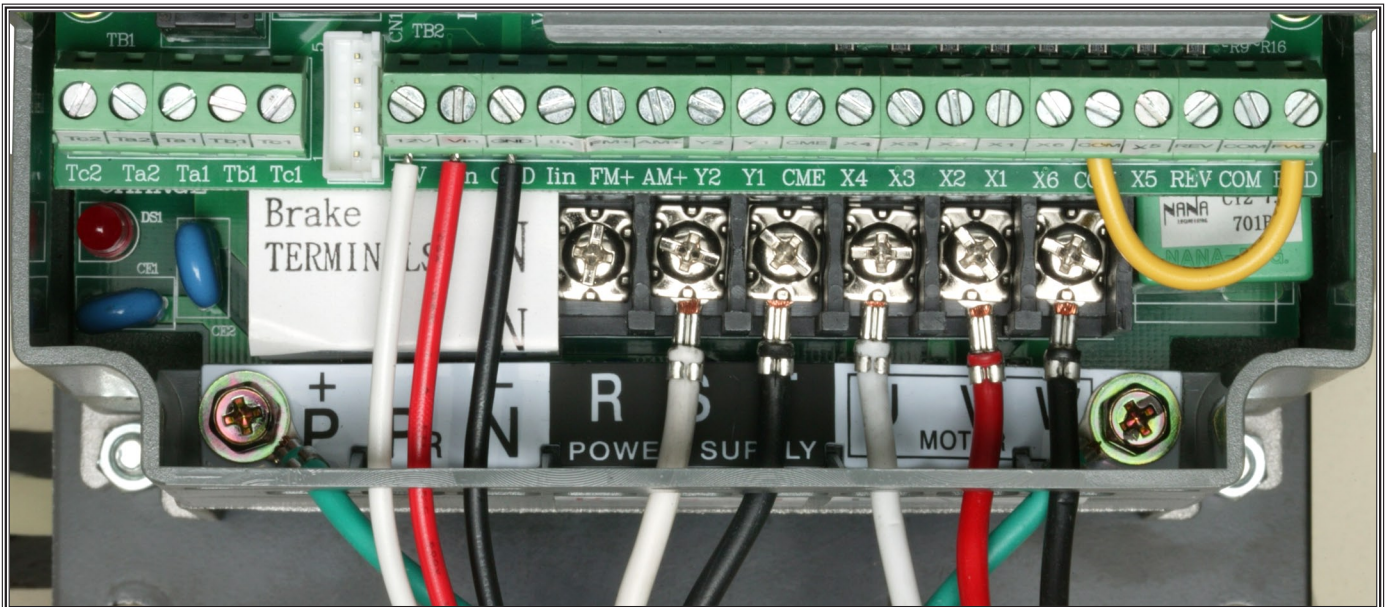
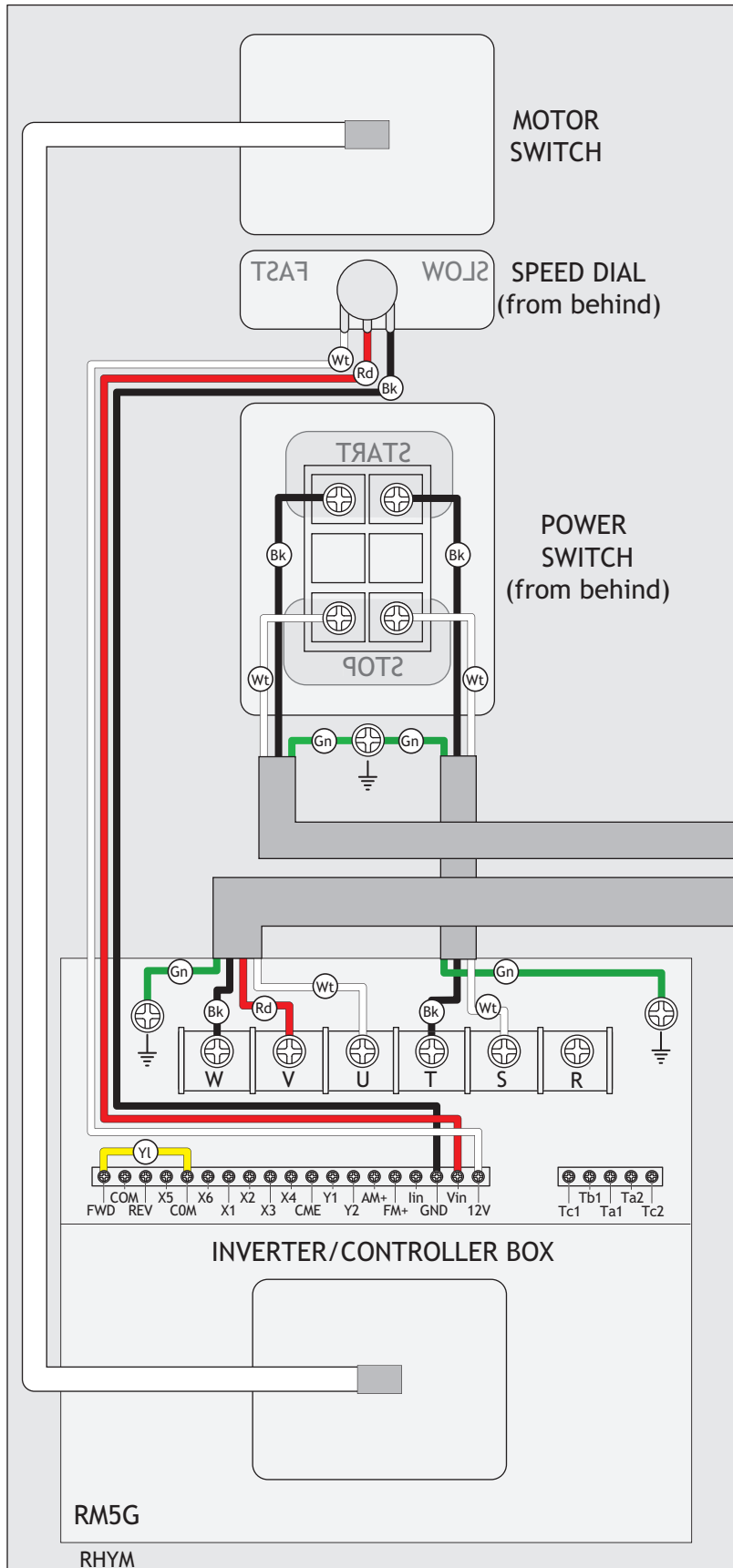

Figure 62. Inverter/controller box terminal blocks.

Wiring Diagram



⚠ DANGER
SHOCK HAZARD!
Disconnect power before servicing electrical parts. Touching electrified parts will result in severe burns, electrocution, or death.

COLOR KEY

BLACK	
WHITE	
GREEN	
RED	
YELLOW	

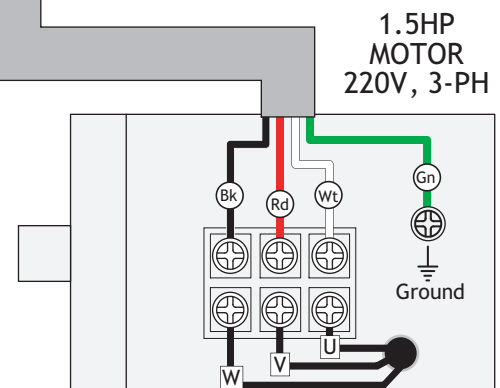
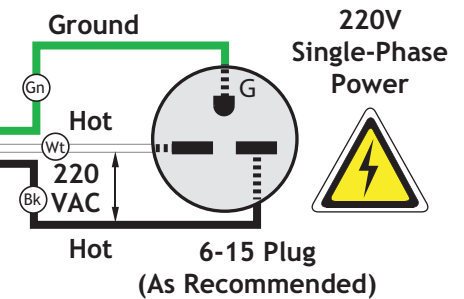

NOTICE
The motor wiring shown here is current at the time of printing, but it may not match your machine. Always use the wiring diagram inside the motor junction box.

SERVICE

Troubleshooting

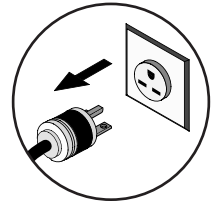

This section covers the most common problems and corrections with this type of machine. **WARNING! DO NOT** make any adjustments until power is disconnected and moving parts have come to a complete stop!

Motor & Electrical

PROBLEM	POSSIBLE CAUSE	CORRECTIVE ACTION
Machine does not start or a breaker trips.	<ol style="list-style-type: none"> 1. OFF button has not been reset. 2. Plug/receptacle is at fault or wired incorrectly. 3. Motor connection wired incorrectly. 4. Wall fuse/circuit breaker is blown/tripped. 5. Power supply switched OFF or is at fault. 6. Wiring is open/has high resistance. 7. Motor ON button or ON/OFF switch is at fault. 8. Inverter/Controller box is at fault. 9. Motor is at fault. 	<ol style="list-style-type: none"> 1. Lift paddle and press OFF button down completely until it clicks. 2. Test for good contacts; correct the wiring. 3. Correct motor wiring connections. 4. Ensure circuit size is suitable for this machine; replace weak breaker. 5. Ensure power supply is switch on; ensure power supply has the correct voltage. 6. Check for broken wires or disconnected/corroded connections, and repair/replace as necessary. 7. Replace faulty ON button or ON/OFF switch. 8. Inspect inverter/controller box; replace if faulty. 9. Test/repair/replace.
Machine stalls or is under-powered.	<ol style="list-style-type: none"> 1. Feed rate/cutting speed too fast for task. 2. Machine is undersized for the task. 3. Blade is slipping on wheels. 4. Motor connection is wired incorrectly. 5. Plug/receptacle is at fault. 6. Pulley/sprocket slipping on shaft. 7. Motor is at fault. 	<ol style="list-style-type: none"> 1. Decrease feed rate/cutting speed. 2. Use sharp blade with lower TPI; reduce the feed rate/depth of cut. 3. Adjust blade tracking and tension to factory specifications. 4. Correct motor wiring connections. 5. Test for good contacts; correct the wiring. 6. Replace loose pulley/shaft. 7. Test/repair/replace.
Machine has vibration or noisy operation.	<ol style="list-style-type: none"> 1. Motor or component is loose. 2. Blade weld is at fault or teeth are broken. 3. Blade is at fault. 4. V-belt worn or loose. 5. Pulley is loose. 6. Motor mount loose/broken. 7. Machine is incorrectly mounted or sits unevenly. 8. Motor fan is rubbing on fan cover. 9. Motor bearings are at fault. 	<ol style="list-style-type: none"> 1. Inspect/replace stripped or damaged bolts/nuts, and re-tighten with thread locking fluid. 2. Replace blade. 3. Replace warped, bent, or twisted blade; sharpen dull blade. 4. Inspect/replace belt. 5. Realign/replace shaft, pulley, setscrew, and key as required. 6. Tighten/replace. 7. Tighten/replace anchor studs in floor; relocate/shim machine. 8. Replace dented fan cover; replace loose/damaged fan. 9. Test by rotating shaft; rotational grinding/loose shaft requires bearing replacement.

Cutting Operations

PROBLEM	POSSIBLE CAUSE	CORRECTIVE ACTION
Machine slows when operating.	<ol style="list-style-type: none"> 1. Feeding workpiece too fast. 2. Blade is dull. 	<ol style="list-style-type: none"> 1. Reduce feed rate. 2. Replace blade (Page 34).
Ticking sound when the saw is running.	<ol style="list-style-type: none"> 1. Blade weld contacting guide/support bearings (a light tick is normal). 2. Blade weld may be failing. 	<ol style="list-style-type: none"> 1. Use file or stone to smooth and round the back of the blade; slightly loosen the blade guides. 2. Inspect and replace blade if necessary (Page 34).
Blade contacting table insert.	<ol style="list-style-type: none"> 1. Insert installed upside down or backwards. 2. Table improperly mounted or aligned. 	<ol style="list-style-type: none"> 1. Re-install insert a different way. 2. Align table (Page 23).
Vibration when cutting.	<ol style="list-style-type: none"> 1. Loose or damaged blade. 2. Sawdust buildup on wheels. 	<ol style="list-style-type: none"> 1. Tighten or replace blade (Page 34). 2. Clean all sawdust from rubber tires on wheels.
Burn marks on the edge of the cut.	<ol style="list-style-type: none"> 1. Too much side pressure when feeding workpiece; blade is binding. 2. Blade too wide for size of radius being cut. 	<ol style="list-style-type: none"> 1. Feed workpiece straight into the blade. See Basic Cutting Tips on Page 27. 2. Install a smaller width blade/increase blade tension. See Page 34 or 19.
Rough or poor quality cuts.	<ol style="list-style-type: none"> 1. Feeding workpiece too fast. 2. Blade guides adjusted incorrectly. 	<ol style="list-style-type: none"> 1. Reduce feed rate. 2. Re-adjust all blade guides and support bearings.
Sawdust buildup inside cabinet.	<ol style="list-style-type: none"> 1. Clogged dust port. 2. Low CFM (airflow) from the shop vacuum. 	<ol style="list-style-type: none"> 1. Clean out dust port. 2. Two options: <ul style="list-style-type: none"> –Check dust hoses for leaks or clogs. –Connect saw to a more powerful shop vacuum.
Blade wanders or doesn't cut straight.	<ol style="list-style-type: none"> 1. Blade lead. 2. Sawdust buildup on wheels. 	<ol style="list-style-type: none"> 1. Refer to Blade Lead on Page 40. 2. Clean all sawdust from rubber tires on wheels.
Cuts are not square (vertically).	<ol style="list-style-type: none"> 1. Table tilt is not adjusted to 0° or positive stop has moved out of adjustment. 2. Table tilt scale pointer is not calibrated. 3. Table is not square to the blade. 	<ol style="list-style-type: none"> 1. Adjust table tilt to 0°; readjust positive stop if necessary (Page 22). 2. Calibrate table tilt scale pointer to 0° (Page 22). 3. Shim table (Page 40).
Metal chips are silvery, thin, small, or powdery.	<ol style="list-style-type: none"> 1. Feed rate too slow. 2. Blade speed too fast. 	<ol style="list-style-type: none"> 1. Increase feed rate. 2. Decrease blade speed.
Metal chips are large, curled, blue/brown or smoking.	<ol style="list-style-type: none"> 1. Feed rate too fast. 2. Blade speed too slow. 	<ol style="list-style-type: none"> 1. Decrease feed rate. 2. Increase blade speed.

Miscellaneous

PROBLEM	POSSIBLE CAUSE	CORRECTIVE ACTION
Blade tension scale is grossly inaccurate.	1. The spring in the blade tension mechanism has lost its "spring." This is caused by not releasing the blade tension when not in use or frequently over-tensioning the bandsaw.	1. Replace spring in the blade tension mechanism, then take better care of the bandsaw by releasing tension when not in use and not over-tensioning the blade.
Wheel is noisy.	<ol style="list-style-type: none"> 1. Wheel bearing is worn out. 2. Belt is too tight (lower wheel). 	<ol style="list-style-type: none"> 1. Replace the wheel bearing. 2. Check/loosen the belt tension (Page 38).
Blade does not track consistently, correctly, or at all.	<ol style="list-style-type: none"> 1. Wheels are not coplanar or aligned with each other. 2. Rubber tires on wheels are worn out. 	<ol style="list-style-type: none"> 1. Adjust wheels to be coplanar/aligned with each other (Page 42). 2. Redress the rubber tires on the wheels (Page 37); replace the rubber tires on the wheels.

PARTS

Bandsaw Body Breakdown

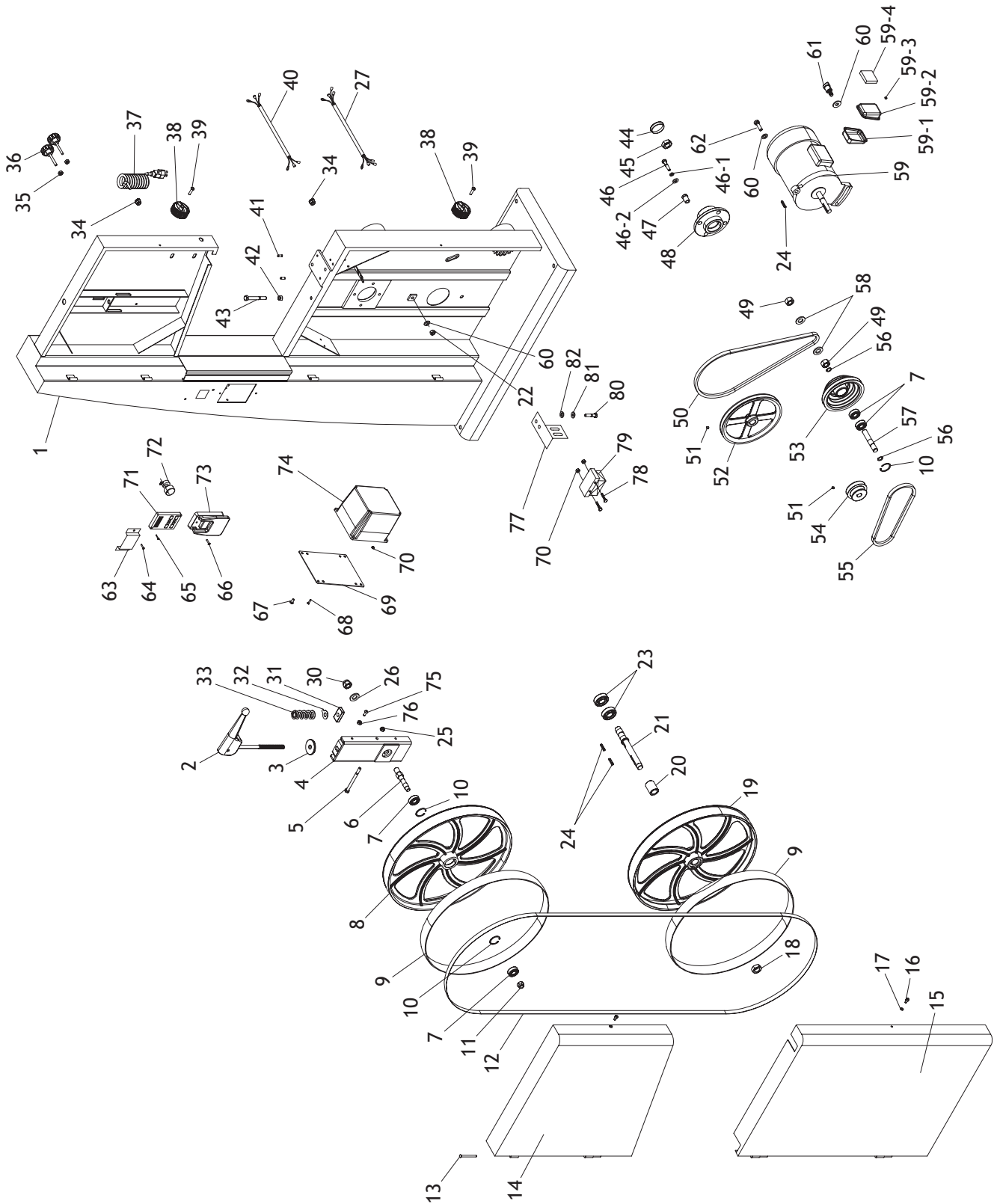

Bandsaw Body Parts List

REF	PART #	DESCRIPTION	REF	PART #	DESCRIPTION
1	XM1113001	BODY	46	XPB11	HEX BOLT 5/16-18 X 1-1/2
2	XM1113002	BLADE TENSION HANDLE	46-1	XPNO2	HEX NUT 5/16-18
3	XM1113003	TENSION HANDLE WASHER	46-2	XPW07	FLAT WASHER 5/16
4	XM1113004	UPPER WHEEL BRACKET	47	XM1113047	ADJUSTING SCREW
5	XM1113005	HEX BOLT M8-1.25 X 110	48	XM1113048	BEARING HOUSING
6	XM1113006	UPPER WHEEL SHAFT	49	XPNO4	HEX NUT 5/8-11
7	XP620ZZ	BALL BEARING 620ZZ	50	XPVA41	V-BELT A-41 4L410
8	XM1113008	UPPER WHEEL	51	XPSS03	SET SCREW 1/4-20 X 3/8
9	XM1113009	TIRE	52	XM1113052	WHEEL PULLEY
10	XPR21M	INT RETAINING RING 35MM	53	XM1113053	IDLER PULLEY
11	XPLN08	LOCK NUT 1/2-20	54	XM1113054	MOTOR PULLEY
12	XM1113012	BLADE 133" LONG	55	XPVA30	V-BELT A-30 4L300
13	XM1113013	WHEEL GUARD HINGE PIN	56	XPR05M	EXT RETAINING RING 15MM
14	XM1113014	UPPER WHEEL GUARD	57	XM1113057	IDLER PULLEY SHAFT
15	XM1113015	LOWER GUARD	58	XPW14	FLAT WASHER 5/8
16	XPSB05	CAP SCREW 1/4-20 X 3/4	59	XM1113059	MOTOR 1.5HP 220V 3-PH
17	XPNO5	HEX NUT 1/4-20	59-1	XM1113059-1	JUNCTION BOX REAR COVER
18	XPNO42	HEX NUT 3/4-10 (LH)	59-2	XM1113059-2	JUNCTION BOX FRONT COVER
19	XM1113019	LOWER WHEEL	59-3	XPS18	PHLP HD SCR 10-24 X 1/4
20	XM1113020	SPACER	59-4	XM1113059-4	3-CIRCUIT TERMINAL BLOCK
21	XM1113021	LOWER WHEEL SHAFT	60	XPW02	FLAT WASHER 3/8
22	XPNO8	HEX NUT 3/8-16	61	XM1113061	SPECIAL SCREW 3/8-16 X 1-1/4
23	XP6204	BALL BEARING 6204ZZ	62	XPB35	HEX BOLT 3/8-16 X 2-1/2
24	XPK23M	KEY 5 X 5 X 25	63	XM1113063	SWITCH COVER
25	XPNO3M	HEX NUT M8-1.25	64	XPS17M	PHLP HD SCR M4-.7 X 6
26	XPLW07	LOCK WASHER 1/2	65	XPS109M	PHLP HD SCR M3-.5 X 18
27	XM1113027	CORD 4-WIRE 16AWG	66	XPS01M	PHLP HD SCR M4-.7 X 18
30	XPLN08	LOCK NUT 1/2-20	67	XPS04	PHLP HD SCR 1/4-20 X 1/2
31	XM1113031	PLATE NUT	68	XPS08	PHLP HD SCR 10-24 X 3/4
32	XM1113032	BLADE TENSION POINTER	69	XM1113069	CONTROLLER COVER PLATE
33	XM1113033	COMPRESSION SPRING	70	XPNO7	HEX NUT 10-24
34	XM1113034	STRAIN RELIEF	71	XM1113071	MOTOR INVERTER SWITCH
35	XPNO2	HEX NUT 5/16-18	72	XM1113072	SPEED DIAL
36	XM1113036	BLADE TRACKING KNOB	73	XM1113073	SWITCH W/LARGE STOP
37	XM1113037	POWER CORD 3-WIRE 16AWG	74	XM1113074	INVERTER RHYMEBUS RMG-5 1HP
38	XM1113038	DOOR COVER KNOB	75	XPB03	HEX BOLT 5/16-18 X 1
39	XPSB05	CAP SCREW 1/4-20 X 3/4	76	XPNO2	HEX NUT 5/16-18
40	XM1113040	CORD 3-WIRE 16AWG	77	XM1113077	BRUSH BASE
41	XM1113041	PIN 6MM	78	XPS10	PHLP HD SCR 10-24 X 1-1/2
42	XPNO8	HEX NUT 3/8-16	79	XM1113079	BRUSH
43	XM1113043	HEX BOLT 3/8-16 X 4	80	XPB19	HEX BOLT 1/4-20 X 1/2
44	XM1113044	COVER	81	XPLW02	LOCK WASHER 1/4
45	XPNO3	HEX NUT 3/4-16	82	XPW06	FLAT WASHER 1/4

Table & Guides Breakdown

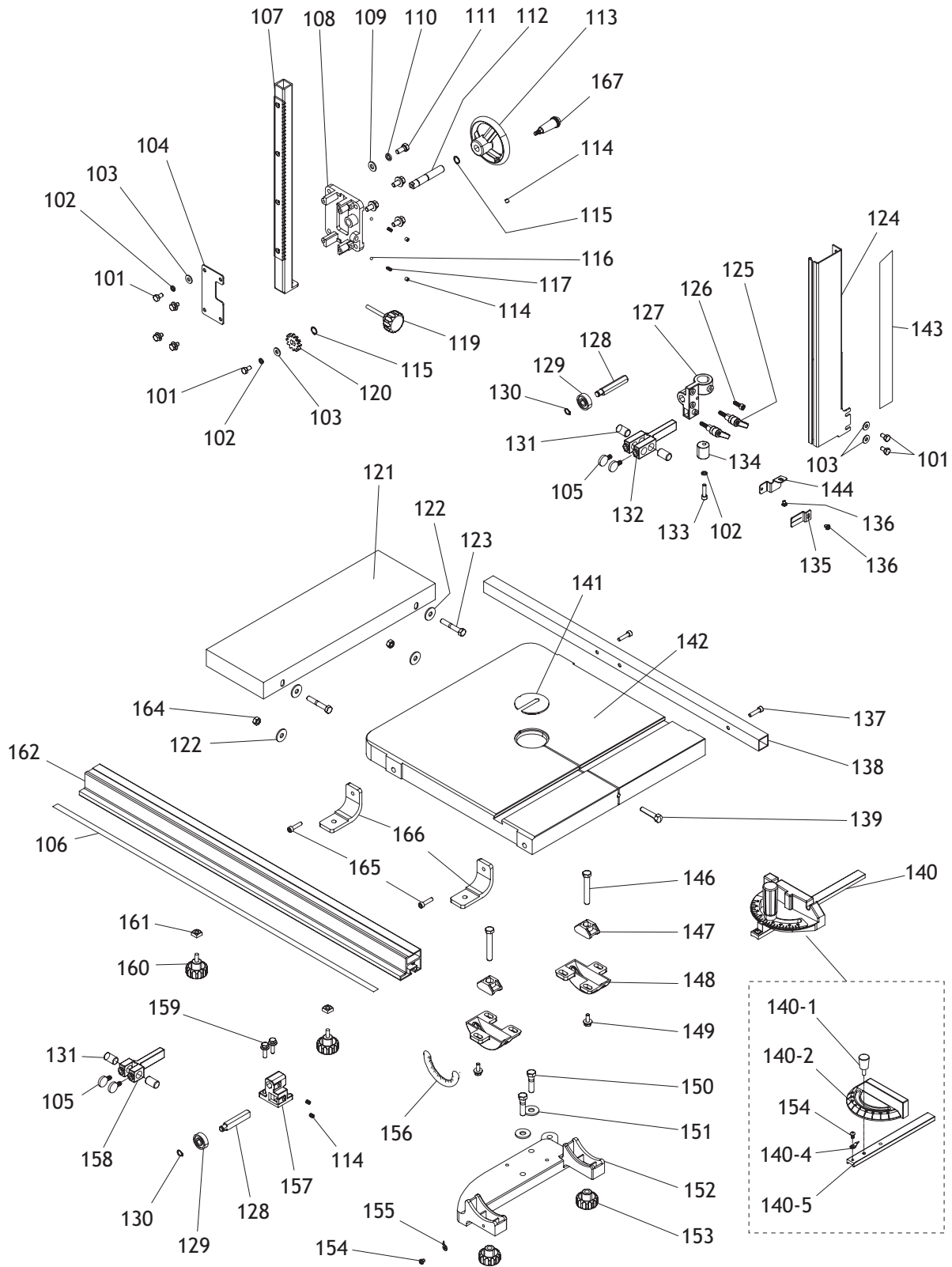
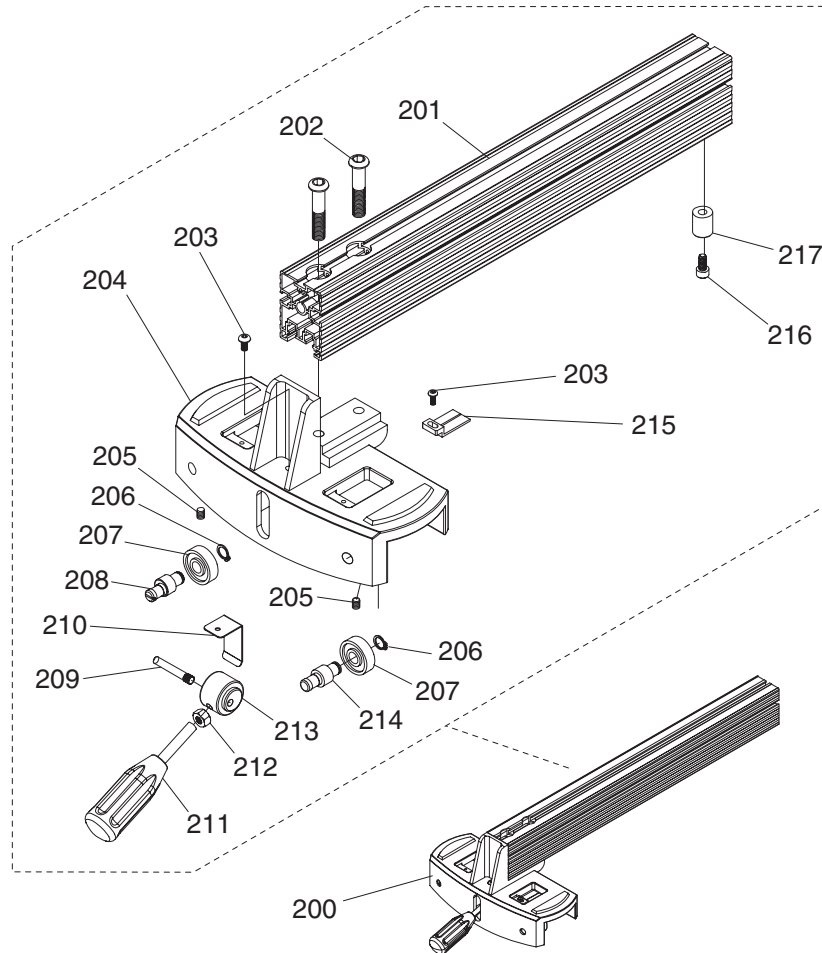

Table & Guides Parts List

REF	PART #	DESCRIPTION
101	XPB51	HEX BOLT 1/4-20 X 3/8
102	XLPLW02	LOCK WASHER 1/4
103	XPW06	FLAT WASHER 1/4
104	XM1113104	GUIDE BAR COVER
105	XPTS001	THUMB SCREW 1/4-20 X 1/2
106	XM1113106	FENCE SCALE
107	XM1113107	GUIDE BAR
108	XM1113108	GUIDE BAR BRACKET
109	XPW07	FLAT WASHER 5/16
110	XLPLW01	LOCK WASHER 5/16
111	XPB32	HEX BOLT 5/16-18 X 5/8
112	XM1113112	HANDWHEEL SHAFT
113	XM1113113	HANDWHEEL
114	XPSS11	SET SCREW 1/4-20 X 1/4
115	XPR47M	EXT RETAINING RING 13MM
116	XM1113116	BALL
117	XM1113117	COMPRESSION SPRING
119	XM1113119	GUIDE BAR KNOB 5/16-18 X 2
120	XM1113120	GEAR
121	XM1113121	EXTENSION TABLE
122	XPW07	FLAT WASHER 5/16
123	XPB06	HEX BOLT 5/16-18 X 2
124	XM1113124	BLADE COVER
125	XM1113125	LOCK LEVER 1/4-20 X 3/4
126	XPSB05	CAP SCREW 1/4-20 X 3/4
127	XM1113127	GUIDE POST BRACKET
128	XM1113128	SUPPORT BEARING SHAFT
129	P6200	BALL BEARING 6200ZZ
130	XPR01M	EXT RETAINING RING 10MM
131	XM1113131	BLADE GUIDE BLOCK
132	XM1113132	BLADE GUIDE HOLDER TOP
133	XPSB06	CAP SCREW 1/4-20 X 1
134	XM1113134	GUIDE POST
135	XM1113135	GUIDE HEIGHT POINTER

REF	PART #	DESCRIPTION
136	XPS01	PHLP HD SCR 10-24 X 1/2
137	XPSB06	CAP SCREW 1/4-20 X 1
138	XM1113138	REAR RAIL
139	XM1113139	TABLE PIN
140	XM1113140	GAUGE
140-1	XM1113140-1	MITER GAUGE HANDLE
140-2	XM1113140-2	MITER GAUGE BODY
140-4	XM1113140-4	MITER GAUGE POINTER
140-5	XM1113140-5	MITER GAUGE BAR
141	XM1113141	TABLE INSERT
142	XM1113142	TABLE (19MM T-SLOT)
143	XM1113143	GUIDE BAR SCALE
144	XM1113144	POINTER PLATE
146	XPB35	HEX BOLT 3/8-16 X 2-1/2
147	XM1113147	CLAMP SHOE
148	XM1113148	TRUNNION
149	XPB07	HEX BOLT 5/16-18 X 3/4
150	XPB58	HEX BOLT 3/8-16 X 2
151	XPW02	FLAT WASHER 3/8
152	XM1113152	TABLE BRACKET
153	XM1113153	TABLE TRUNNION KNOB 3/8-16
154	XPS18	PHLP HD SCR 10-24 X 1/4
155	XM1113155	TABLE TILT POINTER
156	XM1113156	TABLE TILT SCALE
157	XM1113157	LOWER SUPPORT BRACKET
158	XM1113158	BLADE GUIDE HOLDER BOTTOM
159	XPB05	HEX BOLT 1/4-20 X 3/4
160	XM1113160	RAIL KNOB 5/16-18 X 5/8
161	XPSN01	SQUARE NUT 3/8-16
162	XM1113162	FRONT RAIL
164	XPNO2	HEX NUT 5/16-18
165	XPSB06	CAP SCREW 1/4-20 X 1
166	XM1113166	L-BRACKET
167	XM1113167	HANDWHEEL HANDLE

Fence Breakdown



REF	PART #	DESCRIPTION
200	XM1113200	FENCE ASSY
201	XM1113201	FENCE BODY
202	XPSB64M	CAP SCREW M10-1.5 X 25
203	XPSB511M	BUTTON HD CAP SCR M6-1 X 10
204	XM1113204	FENCE BASE
205	XPSS11	SET SCREW 1/4-20 X 1/4
206	XPR01M	EXT RETAINING RING 10MM
207	XP6200	BALL BEARING 6200ZZ
208	XM1113208	ECCENTRIC SHAFT

REF	PART #	DESCRIPTION
209	XM1113209	PIN 6 X 43
210	XM1113210	PLATE
211	XM1113211	FENCE LOCK HANDLE
212	XPNO3M	HEX NUT M8-1.25
213	XM1113213	LOCK MECHANISM
214	XM1113214	BEARING SHAFT
215	XM1113215	FENCE SCALE INDICATOR PLATE
216	XPSB04M	CAP SCREW M6-1 X 10
217	XM1113217	RUNNER

Label Placement

⚠️ WARNING

Safety labels warn about machine hazards and how to prevent machine damage or injury. The owner of this machine **MUST** maintain the original location and readability of all labels on this machine. If any label is removed or becomes unreadable, **REPLACE** that label before allowing the machine to enter service again. Contact Woodstock International, Inc. at (360) 734-3482 or www.shopfoxtools.com to order new labels.

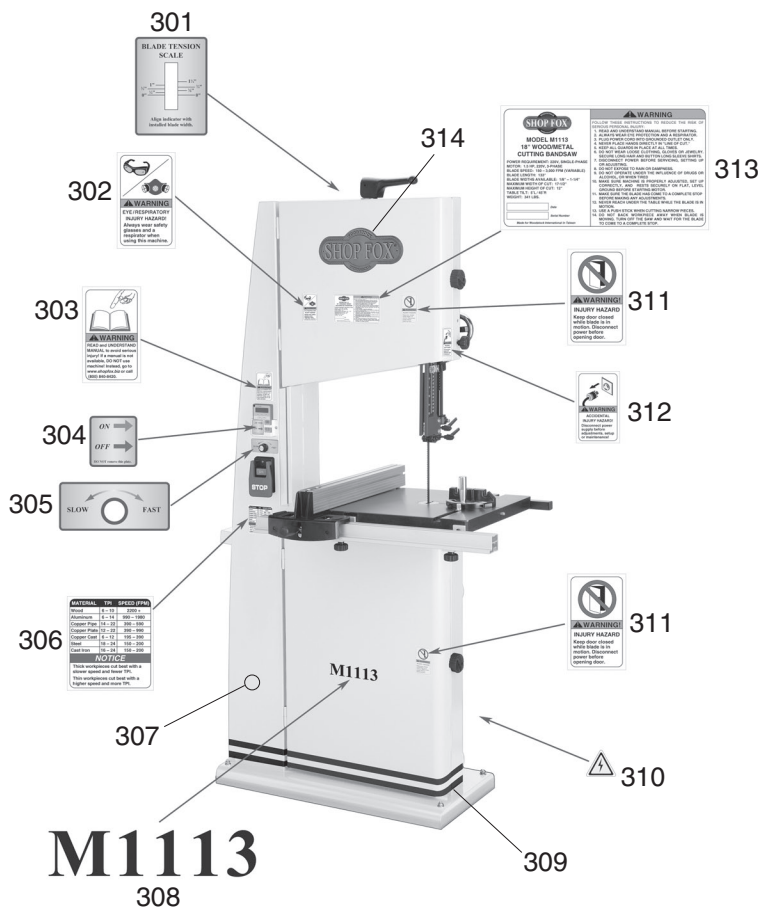

REF	PART #	DESCRIPTION
301	XM1113301	BLADE TENSION SCALE
302	XLABEL-06	GLASSES RESPIRATOR LABEL
303	XLABEL-08	READ MANUAL LABEL
304	XM1113304	MOTOR ON/OFF LABEL
305	XM1113305	VARIABLE SPEED LABEL
306	XM1113306	BLADE SPEED CHART LABEL
307	XPPAINT-1	SHOP FOX WHITE PAINT

REF	PART #	DESCRIPTION
308	XM1113308	M1113 MODEL # LABEL
309	XM1113309	DECORATIVE BLACK STRIPE
310	XLABEL-04	ELECTRICITY LABEL
311	XLABEL-05	DOOR CLOSED LABEL
312	XLABEL-07	UNPLUG POWER LABEL
313	XM1113313	MACHINE ID LABEL
314	XM1113314	SHOP FOX LOGO PLATE



M1113 18" Wood/Metal Bandsaw



Warranty Registration

Name _____
 Street _____
 City _____ State _____ Zip _____
 Phone # _____ Email _____ Invoice # _____
 Model # _____ Serial # _____ Dealer Name _____ Purchase Date _____

The following information is given on a voluntary basis. It will be used for marketing purposes to help us develop better products and services. **Of course, all information is strictly confidential.**

1. How did you learn about us?

<input type="checkbox"/> Advertisement	<input type="checkbox"/> Friend	<input type="checkbox"/> Local Store
<input type="checkbox"/> Mail Order Catalog	<input type="checkbox"/> Website	<input type="checkbox"/> Other:

2. How long have you been a woodworker/metalworker?

<input type="checkbox"/> 0-2 Years	<input type="checkbox"/> 2-8 Years	<input type="checkbox"/> 8-20 Years	<input type="checkbox"/> 20+ Years
------------------------------------	------------------------------------	-------------------------------------	------------------------------------

3. How many of your machines or tools are Shop Fox?

<input type="checkbox"/> 0-2	<input type="checkbox"/> 3-5	<input type="checkbox"/> 6-9	<input type="checkbox"/> 10+
------------------------------	------------------------------	------------------------------	------------------------------

4. Do you think your machine represents a good value? Yes No

5. Would you recommend Shop Fox products to a friend? Yes No

6. What is your age group?

<input type="checkbox"/> 20-29	<input type="checkbox"/> 30-39	<input type="checkbox"/> 40-49
<input type="checkbox"/> 50-59	<input type="checkbox"/> 60-69	<input type="checkbox"/> 70+

7. What is your annual household income?

<input type="checkbox"/> \$20,000-\$29,000	<input type="checkbox"/> \$30,000-\$39,000	<input type="checkbox"/> \$40,000-\$49,000
<input type="checkbox"/> \$50,000-\$59,000	<input type="checkbox"/> \$60,000-\$69,000	<input type="checkbox"/> \$70,000+

8. Which of the following magazines do you subscribe to?

<input type="checkbox"/> Cabinet Maker	<input type="checkbox"/> Popular Mechanics	<input type="checkbox"/> Today's Homeowner
<input type="checkbox"/> Family Handyman	<input type="checkbox"/> Popular Science	<input type="checkbox"/> Wood
<input type="checkbox"/> Hand Loader	<input type="checkbox"/> Popular Woodworking	<input type="checkbox"/> Wooden Boat
<input type="checkbox"/> Handy	<input type="checkbox"/> Practical Homeowner	<input type="checkbox"/> Woodshop News
<input type="checkbox"/> Home Shop Machinist	<input type="checkbox"/> Precision Shooter	<input type="checkbox"/> Woodsmith
<input type="checkbox"/> Journal of Light Cont.	<input type="checkbox"/> Projects in Metal	<input type="checkbox"/> Woodwork
<input type="checkbox"/> Live Steam	<input type="checkbox"/> RC Modeler	<input type="checkbox"/> Woodworker West
<input type="checkbox"/> Model Airplane News	<input type="checkbox"/> Rifle	<input type="checkbox"/> Woodworker's Journal
<input type="checkbox"/> Modeltec	<input type="checkbox"/> Shop Notes	<input type="checkbox"/> Other:
<input type="checkbox"/> Old House Journal	<input type="checkbox"/> Shotgun News	

9. Comments: _____

CUT ALONG DOTTED LINE

FOLD ALONG DOTTED LINE

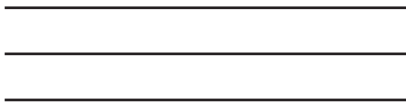

Place
Stamp
Here

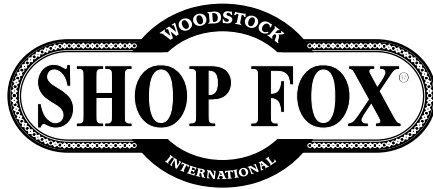

WOODSTOCK INTERNATIONAL INC.
P.O. BOX 2309
BELLINGHAM, WA 98227-2309



FOLD ALONG DOTTED LINE

TAPE ALONG EDGES--PLEASE DO NOT STAPLE

WARRANTY

Woodstock International, Inc. warrants all Shop Fox machinery to be free of defects from workmanship and materials for a period of two years from the date of original purchase by the original owner. This warranty does not apply to defects due directly or indirectly to misuse, abuse, negligence or accidents, lack of maintenance, or reimbursement of third party expenses incurred.

Woodstock International, Inc. will repair or replace, at its expense and at its option, the Shop Fox machine or machine part, which in normal use has proven to be defective, provided that the original owner returns the product prepaid to a Shop Fox factory service center with proof of their purchase of the product within two years, and provides Woodstock International, Inc. reasonable opportunity to verify the alleged defect through inspection. If it is determined there is no defect, or that the defect resulted from causes not within the scope of Woodstock International Inc.'s warranty, then the original owner must bear the cost of storing and returning the product.

This is Woodstock International, Inc.'s sole written warranty and any and all warranties that may be implied by law, including any merchantability or fitness, for any particular purpose, are hereby limited to the duration of this written warranty. We do not warrant that Shop Fox machinery complies with the provisions of any law or acts. In no event shall Woodstock International, Inc.'s liability under this warranty exceed the purchase price paid for the product, and any legal actions brought against Woodstock International, Inc. shall be tried in the State of Washington, County of Whatcom. We shall in no event be liable for death, injuries to persons or property or for incidental, contingent, special or consequential damages arising from the use of our products.

Every effort has been made to ensure that all Shop Fox machinery meets high quality and durability standards. We reserve the right to change specifications at any time because of our commitment to continuously improve the quality of our products.

